

Servodyn-D

Servodyn-D with PROFIBUS-DP interface Commissioning with DSS



Edition

102



BOSCH
Automation

Servodyn-D

Servodyn-D with PROFIBUS-DP interface Commissioning with DSS

1070 066 091-102 (01.08) GB



© 2001

by Robert Bosch GmbH, Erbach / Germany
All rights reserved, including applications for protective rights.
Reproduction or distribution by any means subject to our prior written permission.

Discretionary charge EUR 5.11

Contents

	Page
1	Safety Instructions 1-1
1.1	Intended use 1-1
1.2	Qualified personnel 1-2
1.3	Safety markings on products 1-3
1.4	Safety instructions in this manual 1-4
1.5	Safety instructions concerning the product described 1-5
1.6	Documentation, software release and trademarks 1-7
2	Prerequisites for commissioning 2-1
2.1	Checking the hardware 2-2
2.2	Configuring the PROFIBUS interface at the drive 2-4
2.3	Establishing communication between the drive and DSS 2-5
3	PROFIBUS-DP interface 3-1
3.1	Characteristics 3-1
3.2	Possible modes of the drive 3-2
3.2.1	Motion-controlled mode (MC mode) 3-2
3.2.2	Interpolation in drive 3-5
3.2.3	Velocity control 3-8
3.2.4	Velocity control with actual value feedback 3-10
3.3	Initialization 3-12
3.3.1	Structure of the parameterization data 3-13
3.3.2	Structure of the configuration data 3-14
3.4	Cyclic operation 3-16
3.4.1	Telegram structure: Motion-controlled mode (MC mode) 3-16
3.4.2	Telegram structure: Interpolation in drive 3-17
3.4.3	Telegram structure: Velocity control 3-17
3.4.4	Telegram structure: Velocity control with actual value feedback 3-17
3.5	Diagnostics 3-18
4	DSS user interface 4-1
4.1	DSS basic image 4-1
4.2	DSS monitor 4-4
4.3	Editing/sending *.scs files 4-7
4.4	Selecting the language 4-9
4.5	Changing the user group (password) 4-11
4.6	Important drive commands 4-12
4.6.1	Changing phases 4-12
4.6.2	Save main memory 4-13
4.6.3	Load main memory 4-14
4.6.4	Resetting errors (class 1) 4-15
5	Initial commissioning 5-1
5.1	Setting of basic parameters 5-1
5.2	Enhanced programming 5-4
5.2.1	Initializing absolute encoders 5-4
5.2.2	Digital inputs and outputs (IN x, OUT x) 5-5
5.2.3	Torque monitoring 5-7
5.2.4	Weighting and data reference 5-7
5.2.5	Option OM4: Analog outputs 5-9
5.3	Save all parameter settings (data backup) 5-10

6	Series commissioning	6-1
6.1	Loading files	6-1
6.2	Couple next drive	6-2
7	Test and optimization	7-1
7.1	Optimizing the control unit	7-1
7.1.1	Optimization steps	7-2
7.1.2	DSS tools	7-3
8	Diagnostics	8-1
8.1	Drive configuration / logbook	8-1
8.2	Drive status	8-2
8.3	I/O signals	8-4
8.4	Separate window for cyclic display	8-5
8.5	Updating the parameter values of a *.scs file	8-6
A	Annex	A-1
A.1	Pin assignment of the PROFIBUS-DP interface (X51)	A-1
A.2	Pin assignment of the RS232 interface at the drive (X99)	A-1
A.3	Index	A-2

1 Safety Instructions

Please read this manual before commissioning the Servodyn-D drive. Store this manual in a place to which all users have access at any time.

1.1 Intended use

This manual contains information required for the intended use of this product.

The drive inverters described

- have been developed, manufactured, tested and documented in compliance with the safety standards. These products pose no danger to persons or property if they are used in accordance with the handling stipulations and safety notes prescribed for their configuration, mounting, and proper operation.
- comply with the requirements of
 - the EMC Directives (89/336/EEC, 93/68/EEC and 93/44/EEC)
 - the EMC product standard EN 61800-3 + A11
 - the Low-Voltage Directive (73/23/EEC)
 - the harmonized standards EN 50178 (VDE 0160) and EN 60146-1-1 (VDE 0558-11)
- are designed for operation in industrial environments (emission class A), i.e.
 - no direct connection to public low-voltage power supply,
 - connection to the medium- or high-voltage system via a transformer.In residential environments, in trade and commerce as well as small enterprises class A equipment may only be used if it does not inadmissibly interfere with other equipment.

 **This is a class A device which may cause radio interference in residential environments. In this case, the operator may be required to take suitable countermeasures and to bear the cost of the same.**

Before putting the drive inverters into operation, ensure that the machine which the inverters are to be installed in meets the stipulations of the machinery directive (98/37/EEC, 98/79/EEC) and the EMC directive (89/336/EEC).

The faultless, safe functioning of the product requires proper transport, storage, erection and installation as well as careful operation.

1.2 Qualified personnel

The requirements as to qualified personnel depend on the qualification profiles described by ZVEI (Zentralverband Elektrotechnik und Elektronikindustrie – German Electrical and Electronic Manufacturers' Association) and the VDMA (Verband deutscher Maschinen- und Anlagenbau – German Engineering Federation) in:

Weiterbildung in der Automatisierungstechnik
edited by: ZVEI and VDMA
MaschinenbauVerlag
Postfach 71 08 64
60498 Frankfurt/Germany

The present manual is designed for **drive technicians**. They need special knowledge on PROFIBUS-DP, your PROFIBUS-DP master, and its tools for initializing the interfaces of PROFIBUS-DP slaves connected to the bus.

Programming, start and operation as well as the modification of program parameters is reserved to properly trained personnel! This personnel must be able to judge potential hazards arising from programming, program changes and in general from the mechanical, electrical, or electronic equipment.

Interventions in the hardware and software of our products, unless described otherwise in this manual, are reserved to our specialized personnel.

Tampering with the hardware or software, ignoring warning signs attached to the components, or non-compliance with the warning notes given in this manual may result in serious bodily injury or material damage.

Only electrotechnicians as recognized under IEV 826-09-01 (modified) who are familiar with the contents of this manual may install and service the products described.

Such personnel are

- those who, being well trained and experienced in their field and familiar with the relevant norms, are able to analyze the jobs being carried out and recognize any hazards which may have arisen.
- those who have acquired the same amount of expert knowledge through years of experience that would normally be acquired through formal technical training.

With regard to the foregoing, please note our comprehensive range of training courses. Our training center will be pleased to provide you with further information,
telephone: (+49) (0 60 62) 78-258.

1.3 Safety markings on products



Warning of dangerous electrical voltage!



Electrostatically sensitive components!



Lug for connecting PE conductor only!



Connection of shield conductor only

1.4 Safety instructions in this manual



DANGEROUS ELECTRICAL VOLTAGE

This symbol is used to warn of a **dangerous electrical voltage**. The failure to observe the instructions in this manual in whole or in part may result in **personal injury**.



DANGER

This symbol is used wherever insufficient or lacking compliance with instructions may result in **personal injury**.



CAUTION

This symbol is used wherever insufficient or lacking compliance with instructions may result in **damage to equipment or data files**.

 This symbol is used to draw the user's attention to special circumstances.

★ This symbol is used if user activities are required.

1.5 Safety instructions concerning the product described

**DANGER**

**Danger of life through inadequate EMERGENCY-STOP devices!
EMERGENCY-STOP devices must be active and within reach in all system modes. Releasing an EMERGENCY-STOP device must not result in an uncontrolled restart of the system!
First check the EMERGENCY-STOP circuit, then switch the system on!**

**DANGER**

**Danger for persons and equipment!
Test every new program before starting up a system!**

**DANGER**

**Retrofits or modifications may adversely affect the safety of the products described!
The consequences may include severe injury, damage to equipment, or environmental hazards. Possible retrofits or modifications to the system using third-party equipment therefore have to be approved by Bosch.**

**DANGER**

**Health hazards through destroyed electrical components!
Do not destroy any built-in components. Dispose of destroyed components in a proper manner.**

**DANGER**

Please note your local, system-specific regulations and requirements as well as the proper use of tools, hoisting and transport equipment as well as the applicable standards, regulations, and accident prevention regulations.

**DANGEROUS ELECTRICAL VOLTAGE**

Unless described otherwise, maintenance works must be performed on inactive systems! The system must be protected against unauthorized or accidental reclosing.

Measuring or test activities on the live system are reserved to qualified electrical personnel!

**DANGEROUS ELECTRICAL VOLTAGE**

Lethal voltages of up to 375 V DC against ground on all power connections and DC link connections!

The drives must not be switched on unless all covers have been fitted! When the drive has been disconnected from mains, wait for up to 5 minutes until the system is de-energized before removing any covers.

The drive must always be examined for safe isolation from supply!

**CAUTION**

Use only spare parts approved by Bosch!

**CAUTION**

Observe all precautions for ESD protection when handling modules and components! Avoid electrostatic discharge!

The following protective measures must be observed for modules and components sensitive to electrostatic discharge (ESD)!

- Personnel responsible for storage, transport, and handling must have training in ESD protection.
- ESD-sensitive components must be stored and transported in the prescribed protective packaging.
- ESD-sensitive components may only be handled at special ESD-workplaces.
- Personnel, working surfaces, as well as all equipment and tools which may come into contact with ESD-sensitive components must have the same potential (e.g. by grounding).
- Wear an approved grounding bracelet. The grounding bracelet must be connected with the working surface through a cable with an integrated 1 MΩ resistor.
- ESD-sensitive components may by no means come into contact with chargeable objects, including most plastic materials.
- When ESD-sensitive components are installed in or removed from equipment, the equipment must be de-energized.

1.6 Documentation, software release and trademarks

Documentation

Overview of available manuals:

Manuals	Part no.			
	German	English	French	Italian
Configuration - Manual for overview and rating	1070 066 009	1070 066 029	1070 066 059	1070 066 049
Servo motors SF, SR	1070 066 004	1070 066 024	1070 066 048	1070 066 046
Asynchronous motors DU	1070 066 007	1070 066 027	–	–
Interface conditions	1070 066 010	1070 066 030	1070 066 060	1070 066 050
Interface conditions - Stand alone version	1070 066 016	1070 066 036	1070 066 066	1070 066 056
Servodyn-D, all interfaces - Parameter manual	1070 066 018	1070 066 038	1070 066 068	1070 066 058
Servodyn-D with SERCOS interface - Parameter and commissioning manual	1070 066 011	1070 066 031	–	1070 066 051
Servodyn-D with analog interface - Commissioning manual	1070 066 014	1070 066 034	–	–
Servodyn-D with CANrho interface - Commissioning manual	1070 066 017	1070 066 037	–	–
Servodyn-D with motion control - Commissioning manual	1070 066 015	1070 066 035	–	–
Servodyn-D with PROFIBUS-DP - Commissioning manual	1070 066 090	1070 066 091	–	–
Frequency inverters DM/DS..8001 (ASM) Parameter and commissioning manual	1070 066 008	1070 066 028	–	–
Diagnostics, maintenance	1070 066 012	1070 066 032	1070 066 062	1070 066 052
RSU, Redundant safety monitoring	1070 066 006	1070 066 026	1070 066 081	1070 066 082
EMC manual	1070 066 072	1070 066 074	1070 066 075	1070 066 076
External load switching module	1070 066 077	1070 066 080	–	–

 **In this manual the floppy disk drive is always drive A:, the hard disk drive is always drive C:.**

Special keys or key combinations are shown enclosed in pointed brackets:

- Named keys: e.g., <Return>, <PgUp>,
- Key combinations (pressed simultaneously): e.g., <Ctrl> + <PgUp>

Release

 **The present manual applies to the following releases:**
DM/DS software: 0.001 or higher
DSS software: 2.02 or higher

- The current software release number can be viewed by selecting parameter S-0-0030 with the DSS-D Commissioning and Service System, or in the "Software" field of the module configuration display (DIAGNOSTICS ► MODULE CONFIGURATION).

- For information concerning the current DSS software release, refer to HELP ► ABOUT...
- The current VM software release can only be read from the 7-segment display during test operation.
For this purpose, turn dip switch "T" on the VM's personality module "on":

The following appears in a running, flashing display:
"Cxx.ZZ.ddmmyyyy"

Where: **xx** = software release number
 ZZ = (internal)
 dd = software creation day
 mm = software creation month
 yyyy = software creation year

Modifications

Modifications in the present manual as compared to the previous edition are marked by black vertical bars in the margin.

Trademarks

All trademarks of software installed on Bosch products upon delivery are the property of the respective manufacturer.

Upon delivery, all installed software is copyright-protected. The software may only be reproduced with the approval of Bosch or in accordance with the license agreement of the respective manufacturer.

MS-DOS® and Windows™ are registered trademarks of Microsoft Corporation.

PROFIBUS® is a registered trademark of the PROFIBUS Nutzerorganisation e.V. (user organization).

2 Prerequisites for commissioning

Drive inverters of the Servodyn-D series with PROFIBUS-DP are operated as slaves of a PROFIBUS-DP master.

For the inverters, a GSD file is available (device master data) which contains all data required for operating Servodyn-D on any master compliant to EN 50170-2-DP. The manufacturer of the DP master supplies a suitable configuration tool which you may use to link the drive inverter to the PROFIBUS environment.

 **In this manual, we have assumed that the necessary knowledge for configuring PROFIBUS-DP is available.**

The commissioning procedure comprises the following steps:

- Set PROFIBUS addresses on the drives (S2, S3) and establish PROFIBUS connections (X51).
- Establish communication between the DSS (Diagnostics and Service System) and the drive (X99)
- Load GSD file into the DP master
- Configure PROFIBUS-DP telegrams using the PROFIBUS services "Set_Param" and "Check_Config".
Please note the detailed information provided in section 3.
- Adjust/optimize all required drive parameter values.
This has to be done using the DSS.

 **The DSS is designed for PCs on which the Windows™ operating system has been installed.**

The installation and operation of the DSS requires general knowledge of the Windows user interface (e.g. start/exit programs, open/save files, change program windows, etc.).

In the present manual, we suppose that this knowledge is available.



CAUTION

Commissioning by insufficiently qualified personnel may cause severe damage to the machine and drives or even personal injury!

- **Commissioning is therefore reserved to appropriately trained technical personnel!**
- **For systems comprising several drives, you should always optimize one drive at a time only.**
- **All motors have to be properly fastened.**

Our service department will be pleased to assist you with the commissioning. We may also train your personnel on request. For more information, please contact us (phone +49-(0)6062/78-0)

 **The description of all individual parameters, their mode of functioning and precise programming is included in the "Servodyn-D parameter manual". This description forms the basis of the present manual!**

2.1 Checking the hardware

- ★ First make sure that the system is switched off and de-energized.
- ★ Check the nameplates and the engineering documents for the proper inverter types and the correct motors installed.
Do not continue the commissioning procedure unless the correct hardware has been completely installed!
- ★ Follow the instructions below step by step.

Wiring



CAUTION

Unless specified otherwise, never unplug or plug connectors/terminals on live systems!

- ★ Check the complete wiring of the drives on the basis of the information provided in the "Servodyn-D interface conditions" manual and the "EMC manual" (including resistance measurement).
- ★ Remove all connectors/terminals including the PROFIBUS connector (X51) from all drive inverters.

Power supply

- ★ Turn the 24 V supply on. Measure the voltage of the 24V supply at the connectors.
It must be between 20.8 ... 28.8 V.
 - ★ Turn the power supply on and measure the voltage.
It must be between 342 ... 510 V.
 - ★ Turn the power supply and the 24 V supply off.
Do not proceed unless all connectors/terminals are de-energized.
 - ★ Plug in all connectors/terminals except the PROFIBUS connectors (X51) to the inverters. Check connectors for proper assignment.
 - ★ Turn the 24 V supply on.
The 7-segment display at the inverters must then show "0".
If error "F36" is displayed,
the 24V supply is outside the permissible tolerance, maybe because of a supply overload.
For more information on other error messages, please refer to the diagnostics manual.
-  **Additional information may also be contained in drive parameter S-0-0095. In order to display the parameter on the DSS monitor, communication between the PC and a drive must have been established.**

Plug braking of motors in the event of a power failure

- ★ Check for proper functioning according to planning engineer's data.
If a plug braking resistor is used, an auxiliary contact of the contactor must be provided to ensure that the drive cannot be enabled unless the braking resistor has been deactivated. The "Plug brake enable delay" must be disabled (=0) for this test.
The contactor is driven by output "OUT4" of the inverter.
- ☞ **In order to avoid faults and overload, a relay must be connected in series.**

Holding brake

- ★ Check holding brake for proper functioning if the motor is equipped with a holding brake.
The holding brake is released when 24VDC are connected.
The contactor is triggered by the "OUT3" output of the inverter.
- ☞ **In order to avoid faults and overload, a relay must be connected in series.**

EMERGENCY-STOP circuit

- ★ Check for proper functioning according to planning engineer's data.

Finish checking

- ★ Switch off all voltages.
- ★ If all checks were completed successfully, proceed to the next section. Otherwise, all faults that have occurred must be eliminated.

2.2 Configuring the PROFIBUS interface at the drive

The following settings will not be effective unless the drive has been re-booted. Therefore, they should be made before proceeding with the commissioning process:

- PROFIBUS address
- Mode

PROFIBUS address

- ★ Rotary switches S2 and S3 on the individual inverters are used to set the PROFIBUS address as a 2-digit hexadecimal value. The value setting must be unique, i.e. it may be assigned to a single slave in the PROFIBUS environment only.

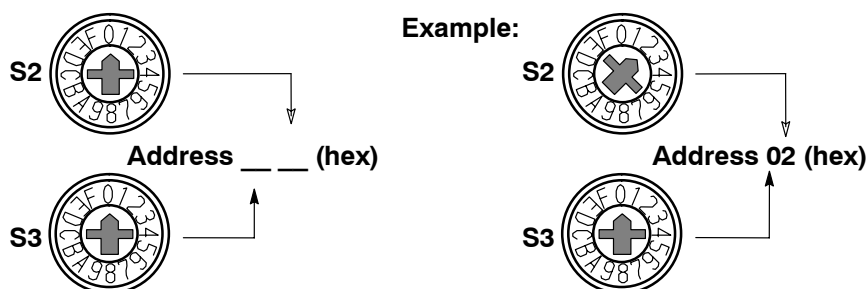

Baudrate

The baudrate set by the master is automatically identified by the drive. Maximum baudrate: 12 MBaud.

Mode

- ★ Set rotary switch S4 to the value "0".

S5	Mode
0	Standard operation
F	Test mode

Connection between master and slave

- ★ Plug the PROFIBUS into the inverter (X51).

☞ For pin assignments and wiring of the X51 PROFIBUS interface, please refer to the annex on page A-1 ff.

2.3 Establishing communication between the drive and DSS

Connection between PC and drive

- ★ To avoid communication faults between the PC and the drive, please note the following:
 - We recommend using the pre-assembled Bosch connection cable, part no.: 1070 077 753, length 5 m
 - Distance between connection cable – power cables: min. 20 cm
 - Do not permit inductive or capacitive coupling with live components.
- ☞ **If communication faults still occur, an annular core on the connection lead may be helpful. Use the folding ferrite coil, part no. 1070 918 766.**
- ★ Connect COM1 or COM2 of the PC to X99 of the first inverter and record the PC port used.
- ☞ **For pin assignments and wiring of the RS232 interface X99, please refer to the annex on page A-1 ff.**

Configuring the interface (DSS)

- ★ Switch on the 24V supply of the system.
If display H1 of the inverter does not show any of the values "0", "2", or "4", check the system as described in section 2.1.
- ★ Switch on the PC. Wait until the operating system has been fully booted and start the "DSS" diagnostics and service system. The "Establish connection" dialog is automatically displayed:

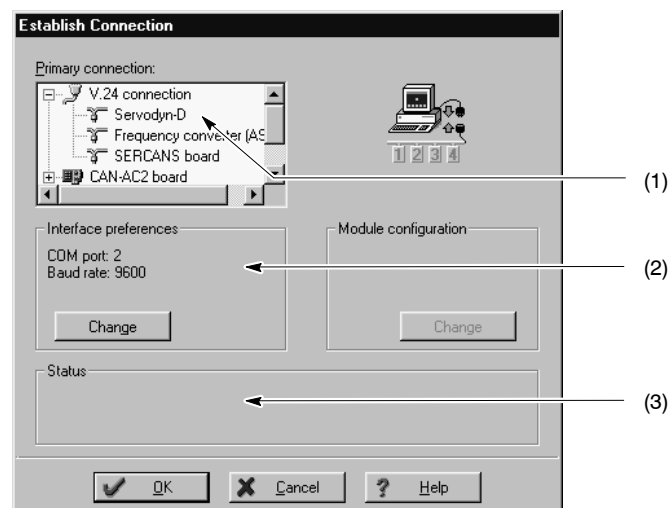

This dialog may also be invoked manually when the connection has been successfully established:

- menu sequence EXTRAS ► INTERFACE SELECT – or –

- Click on  command button in the DSS "Overview" window and select INTERFACE SELECT menu item.

- ★ Select the "V.24 connection" type in the "Primary connection" (1) field, and protocol "Servodyn-D" at the next sublevel.
- ☞ **If no inverter is connected, the DSS may also be operated "offline". In this case, it will simulate an inverter.**
- ★ Make sure that the "Interface preferences" (2) field shows the COM port to which the inverter is actually connected. Otherwise, click on the "Change" command button and select the proper port.

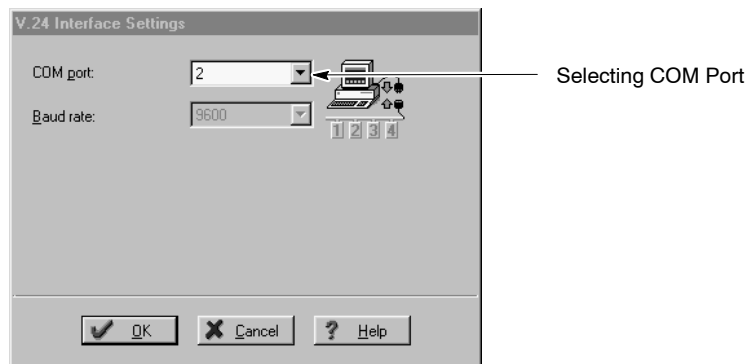

Click on "OK" to accept the selection and return to the "Establish connection" dialog.

- ★ Press "Ok" in the "Establish connection" dialog. The DSS will try to establish the connection selected.
 - In the event of a fault, the "Status" field (3) will contain more information. Check the connection between the PC and the drive and then click on the "Retry" command button.
 - If the connection can be established, the DSS will read information from the drive and then display the "Overview" DSS window.

Reinitializing DSS after module RESET or a module change

If, while DSS is running, you

- disconnect the connection cable from the inverter (e.g. for starting up a new drive), or
 - press the RESET key of the currently connected inverter,
- you then have to re-initialize the DSS. This is the only way to ensure that the DSS does not work with invalid or outdated data.



CAUTION

Possibility of uncontrolled motor movements !

For as long as the drive is enabled, you must neither press the "Reset" key nor disconnect the cable between the DSS and the drive. First stop the movement and disable the drive.

You may reinitialize the DSS by:

- menu sequence
CONTROL ► DSS RESET – or –
- Icon bar: Click on



3 PROFIBUS-DP interface

Section 3 contains a description of

- the drive modes that can be used with the PROFIBUS-DP interface (cf. page 3-2 ff),
- the initialization (cf. page 3-12 ff),
- cyclic operation (cf. page 3-16 ff), and
- the available diagnostic data of the PROFIBUS-DP interface (cf. page 3-18).

3.1 Characteristics

Standards:	IEC 1158-2
Interface type:	PROFIBUS-DP
PROFIBUS services:	Write_Read_Data/Data_Exchange (Default_SAP)
	Read_Inputs (SAP56)
	Read_Outputs (SAP57)
	Global_Control (SAP58)
	Get_Config (SAP59)
	Slave_Diagnosis (SAP60)
	Set_Param (SAP61)
	Check_Config (SAP62)

 **For more information concerning the hardware setting of PROFIBUS interface X51 (address, mode), please refer to page 2-4. Please note that the PROFIBUS address can only be set using rotary switches S2/S3, not via the PROFIBUS service "Set_Slave_Address" (SAP55).**

3.2 Possible modes of the drive

Inverters equipped with PROFIBUS-DP offer the following modes:

- "Motion-controlled mode",
- "Interpolation in drive",
- "Velocity control", or
- "Velocity control with actual value feedback"

3.2.1 Motion-controlled mode (MC mode)

Features:

- Positioning mode with a maximum of 32 motion blocks stored in the drive. Shortest cycle time of the position setpoint generator: 2 ms
- Absolute as well as incremental position inputs are possible
- Path-optimized starting (shortest distance) for absolute position inputs for an endless axis (rotary axis with modulo calculation) possible
- Start, interruption and abortion of a motion
- Referencing
- Jogging

Function:

First, up to 32 blocks consisting of position, velocity, acceleration and deceleration data are uploaded to the drive by the DSS. All block information may also be replaced by the DSS during operation. The changes made will not become effective before the next block is selected.

The following is exchanged cyclically between the master and the drive using the "Data_Exchange" service in order to **control the drive**:

- PROFIBUS control word (P-0-2800)

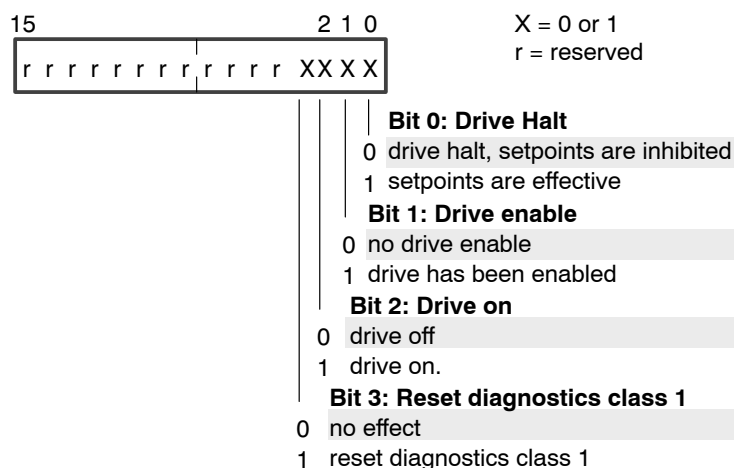

 **Bits 0, 1 and 2 are high:
Power is connected. The motor is controlled.**

- PROFIBUS status word (P-0-2801)

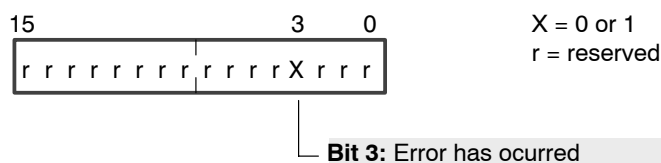

Bit 3: Error has occurred.

Becomes high when the drive has recognized an error situation of diagnostics class 1. The drive is halted in the best possible way; and the torque is removed afterwards.

The following is furthermore exchanged cyclically between the master and the drive using the "Data_Exchange" service especially for **motion-controlled mode**:

- MC mode control word (P-0-2201)
- Block selection (P-0-2203)
- MC mode status word (P-0-2202)

Directly relevant parameters:

- P-0-2800 PROFIBUS control word (bits 0 to 3)
- P-0-2801 PROFIBUS status word (bit 3)
- P-0-2201 MC mode control word
- P-0-2202 MC mode status word
- P-0-2203 Block selection
- P-0-2206 MC mode error
- P-0-2210 Parameter of rotary axis
- P-0-2820 MC mode: Target positions (Weighting S-0-0076)
- P-0-2830 MC mode: Positioning speed (Weighting S-0-0044)
(if not specified, S-0-0259 will be used)
- P-0-2840 MC mode: Positioning acceleration (Weighting S-0-0160)
(if not specified, S-0-0260 will be used)
- P-0-2850 MC mode: Positioning delay (Weighting S-0-0160)
(if not specified, S-0-0260 will be used)
- P-0-2860 MC mode: Positioning control values

Additional parameters used:

- S-0-0103 modulo value
- S-0-0041 Referencing speed
- S-0-0042 Referencing acceleration
- S-0-0147 Referencing parameter
- P-0-0006 Type of position encoder, motor encoder
- S-0-0057 Positioning window, fine
- S-0-0049 Position limit value, positive
- S-0-0050 Position limit value, negative
- S-0-0055 Position polarity parameter
- S-0-0076 Type of weighting for position data
- S-0-0044 Type of weighting for velocity data
- S-0-0160 Type of weighting for acceleration data

 **For more information on these parameters, please refer to the parameter manual.**

Typical signal sequences of control and status bits in automatic mode

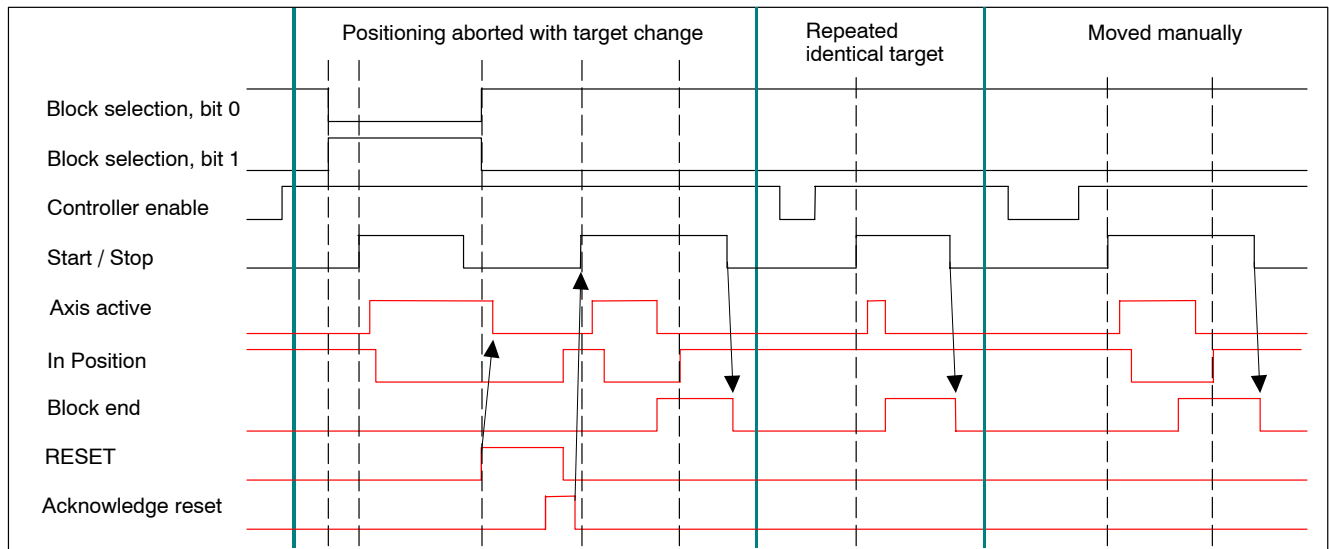
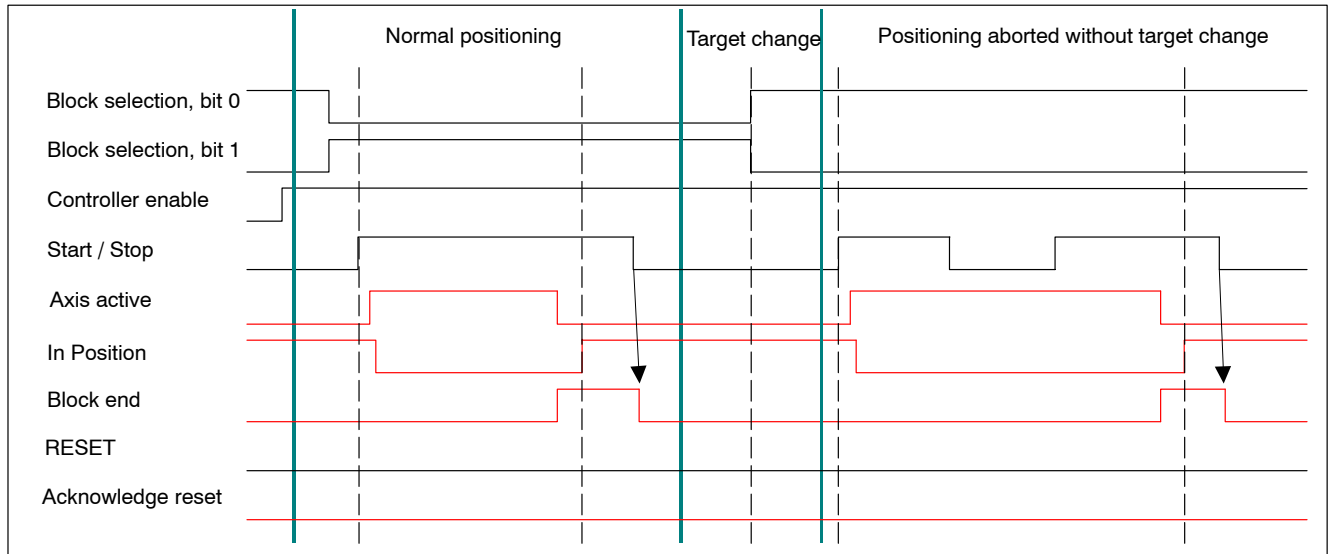

☞ **Bits 0, 1 and 2 are high:
Power is connected. The motor is controlled.**

- PROFIBUS status word (P-0-2801)

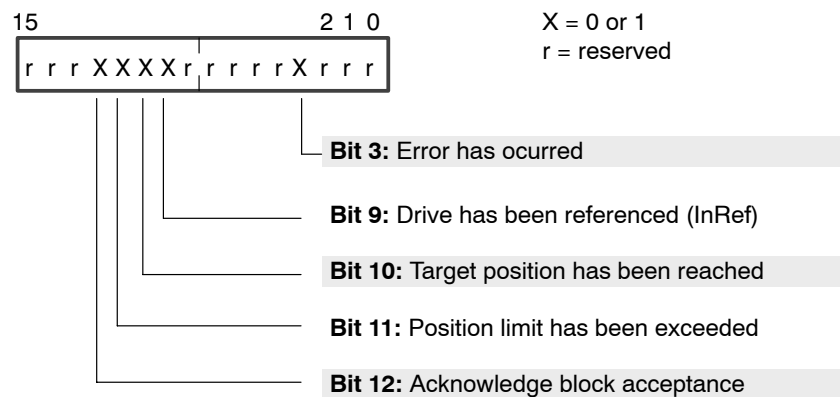

Bit 3: Error has occurred.

Becomes high when the drive has recognized an error situation of diagnostics class 1. The drive is halted in the best possible way; and the torque is removed afterwards.

Bit 9: Drive has been referenced

When switched on, incremental encoders force axis referencing in order to perform a positioning motion.
If the absolute encoder system is active (P-0-0006 = 1), bit 9 is always high.

Bit 10: Target position has been reached.

Bit 10 becomes high as soon as the current position is within the positioning window (S-0-0057), or if bit 11 of P-0-2800 becomes high (clear distance to go). If the distance to go is larger than the positioning window, or after an interruption of the motion (P-0-2800, bit 8 = 1), bit 10 becomes low.

Bit 11: Position limit has been exceeded.

If the drive has been referenced (P-0-2801, bit 9 = 1), bit 11 of P-0-2801 becomes high if the position limit is exceeded (S-0-0049, S-0-0050).

The position limits can be deactivated by S-0-0055 (position polarity parameter).

Bit 12: Acknowledge block acceptance.

Becomes high as soon as new block data have been accepted by the interpolator (also refer to P-0-2800, bit 4, New Setpoint: Initiate block acceptance by positive edge).

If bit 4 of P-0-2800 is reset and the interpolator is ready to accept new block data, the drive also resets bit 12 of P-0-2801

☞ **This meaning of bits 10 to 12 only applies to "Interpolation in the drive". In "Velocity control" mode, the bits are interpreted differently.**

Directly relevant parameters:

- P-0-2800 PROFIBUS control word
- P-0-2801 PROFIBUS status word
- P-0-2810 Target position (Weighting S-0-0076)
- P-0-2811 Positioning speed (Weighting S-0-0044)
- P-0-2812 Positioning acceleration (Weighting S-0-0160)
- P-0-2813 Positioning delay (Weighting S-0-0160)
- S-0-0051 Positioning actual value (Weighting S-0-0076)

Additional parameters used:

- S-0-0041 Referencing speed
- S-0-0042 Referencing acceleration
- S-0-0147 Referencing parameter
- P-0-0006 Type of position encoder, motor encoder
- S-0-0057 Positioning window, fine
- S-0-0049 Position limit value, positive
- S-0-0050 Position limit value, negative
- S-0-0055 Position polarity parameter
- S-0-0076 Type of weighting for position data
- S-0-0044 Type of weighting for velocity data
- S-0-0160 Type of weighting for acceleration data

 **For more information on these parameters, please refer to the parameter manual.**

Typical signal sequences of control and status bits in automatic mode

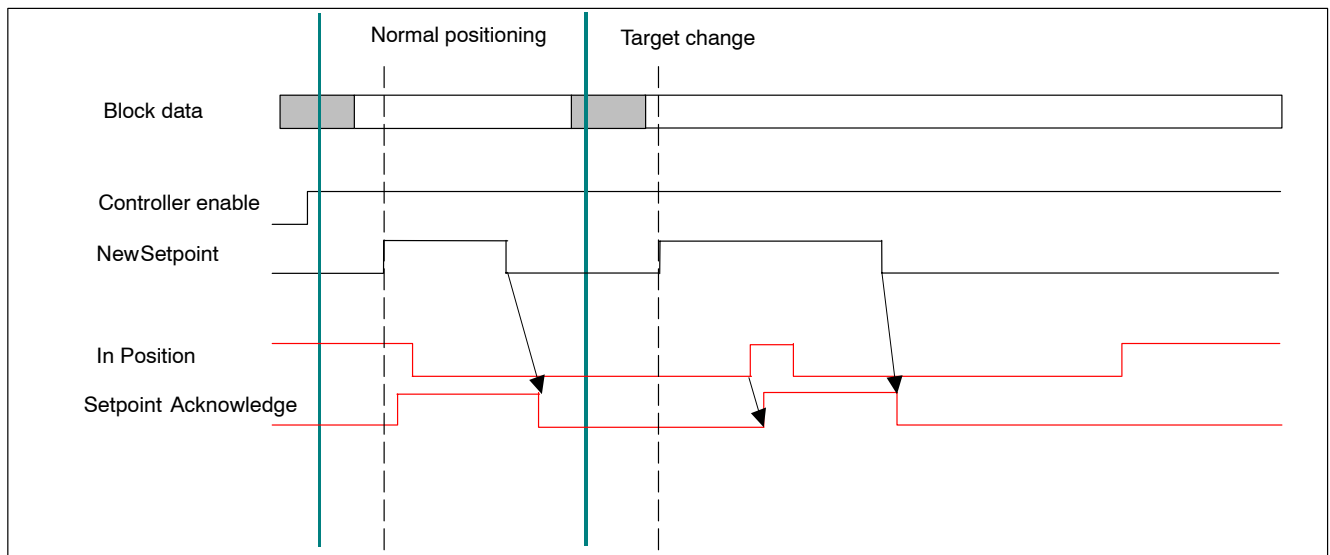

3.2.3 Velocity control

Features:

- Input of a velocity/speed setpoint via PROFIBUS-DP. No feedback of actual values to the master.

Function:

The "PROFIBUS control word" (P-0-2800) and the "PROFIBUS status word" (P-0-2801) are cyclically exchanged between the master and the drive using the "Data_Exchange" service.

The drive stores the setpoint in parameter S-0-0036.

The following is exchanged cyclically between the master and the drive using the "Data_Exchange" service in order to **control the drive** and for special status messages of **velocity control**:

- PROFIBUS control word (P-0-2800)

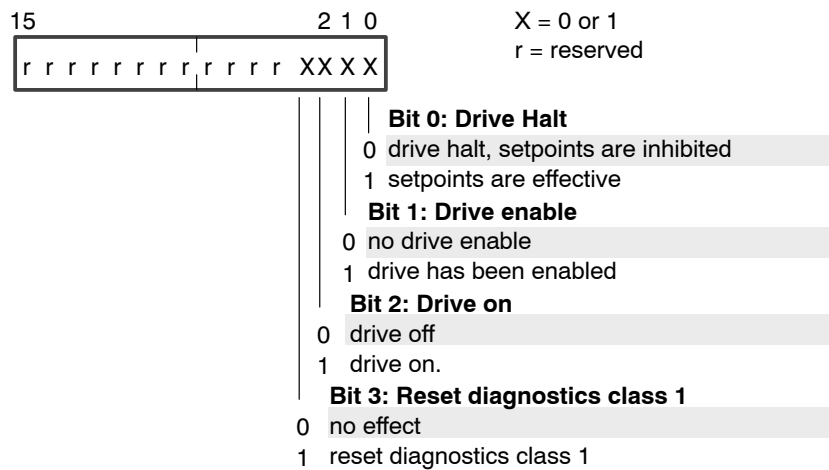

Bits 0, 1 and 2 are high: Power is connected. The motor is controlled.

- PROFIBUS status word (P-0-2801)

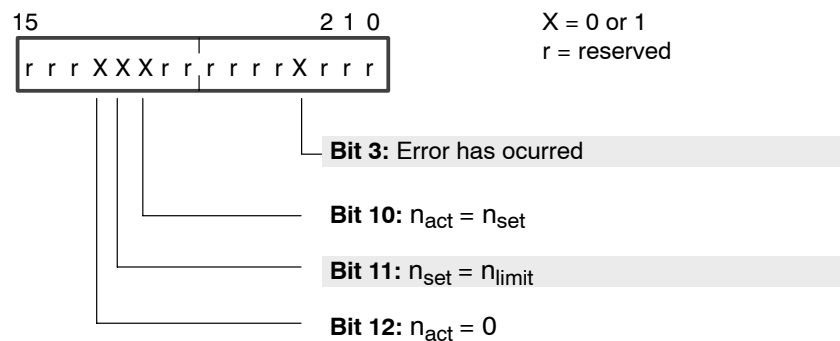

Bit 3: Error has occurred.

Becomes high when the drive has recognized an error situation of diagnostics class 1. The drive is halted in the best possible way; and the torque is removed afterwards.

Bit 10: $n_{act} = n_{set}$

Becomes high as soon as the speed/velocity input value has been reached according to velocity window P-0-0157.

Bit 11: $n_{\text{set}} = n_{\text{limit}}$

Becomes high when the setpoint input is too high, thus being limited to n_{limit} .

Bit 12: $n_{\text{act}} = 0$

Becomes high as soon as the velocity has reached the value 0 according to velocity window P-0-0157.

 **This meaning of bits 10 to 12 only applies to velocity control. In "Interpolation in the drive" mode, the bits are interpreted differently.**

Directly relevant parameters:

- P-0-2800 PROFIBUS control word (bits 0 to 3)
- P-0-2801 PROFIBUS status word (bits 3, 10 to 12)
- S-0-0036 Velocity setpoint (Weighting S-0-0044)

Additional parameters used:

- S-0-0157 Velocity window
- S-0-0044 Type of weighting for velocity data
- S-0-0138 Acceleration bipolar
- S-0-0160 Type of weighting for acceleration data

 **For more information on these parameters, please refer to the parameter manual.**

3.2.4 Velocity control with actual value feedback

Features:

- Input of a velocity/speed setpoint via PROFIBUS-DP
- Feedback of actual velocity/speed values to the master.
- Feedback of actual position value to the master (8192 increments per motor revolution)

Function:

Setpoints, actual values, "PROFIBUS control word" (P-0-2800) and the "PROFIBUS status word" (P-0-2801) are cyclically exchanged between the master and the drive using the "Data_Exchange" service.

The drive stores the setpoint in parameter S-0-0036.

The drive takes the actual velocity/speed value from S-0-0040, and the actual position value from P-0-2816.

The following is exchanged cyclically between the master and the drive using the "Data_Exchange" service in order to **control the drive** and for special status messages of **velocity control with actual value feedback**:

- PROFIBUS control word (P-0-2800)

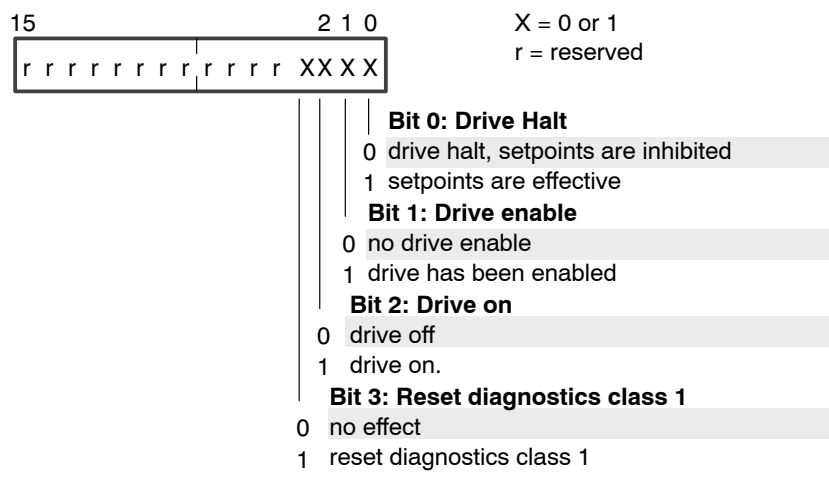

Bits 0, 1 and 2 are high:
Power is connected. The motor is controlled.

- PROFIBUS status word (P-0-2801)

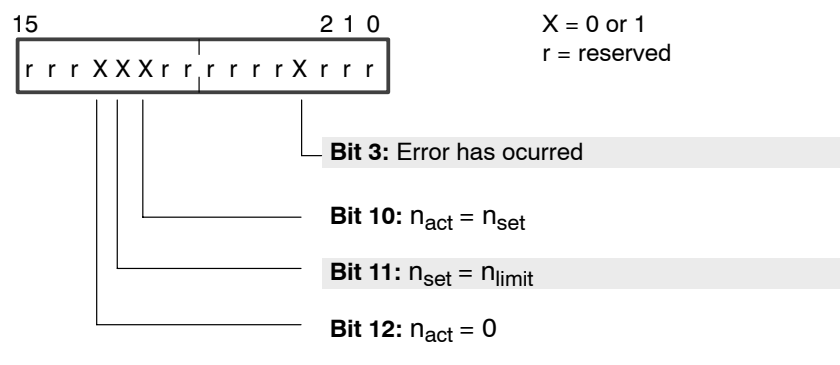

Bit 3: Error has occurred.

Becomes high when the drive has recognized an error situation of diagnostics class 1. The drive is halted in the best possible way; and the torque is removed afterwards.

Bit 10: $n_{act} = n_{set}$

Becomes high as soon as the speed/velocity input value has been reached according to velocity window P-0-0157.

Bit 11: $n_{set} = n_{limit}$

Becomes high when the setpoint input is too high, thus being limited to n_{limit} .

Bit 12: $n_{act} = 0$

Becomes high as soon as the speed has reached the value 0 according to velocity window P-0-0157.

 **This meaning of bits 10 to 12 only applies to velocity control. In "Interpolation in the drive" mode, the bits are interpreted differently.**

Directly relevant parameters:

- P-0-2800 PROFIBUS control word (bits 0 to 3)
- P-0-2801 PROFIBUS status word (bits 3, 10 to 12)
- S-0-0036 Velocity setpoint (Weighting S-0-0044)
- S-0-0040 Actual velocity value (Weighting S-0-0044)
- P-0-2816 Actual position value, depends on multiplication S-0-0256:
with S-0-0256 = 4: 8192 increments per motor revolution,
with S-0-0256 = 512: 1,048,576 increments per motor revolution

Additional parameters used:

- S-0-0157 Velocity window
- S-0-0044 Type of weighting for velocity data
- S-0-0138 Bipolar acceleration
- S-0-0160 Type of weighting for acceleration data
- S-0-0256 Multiplication-1 (motor encoder)

 **For more information on these parameters, please refer to the parameter manual.**

3.3 Initialization

When the drive is booted, the following services are used to initialize communication via PROFIBUS-DP:

- Set_Param (SAP61)
- Check_Config (SAP62)

During this time, display H1 at the inverter shows the value "2".

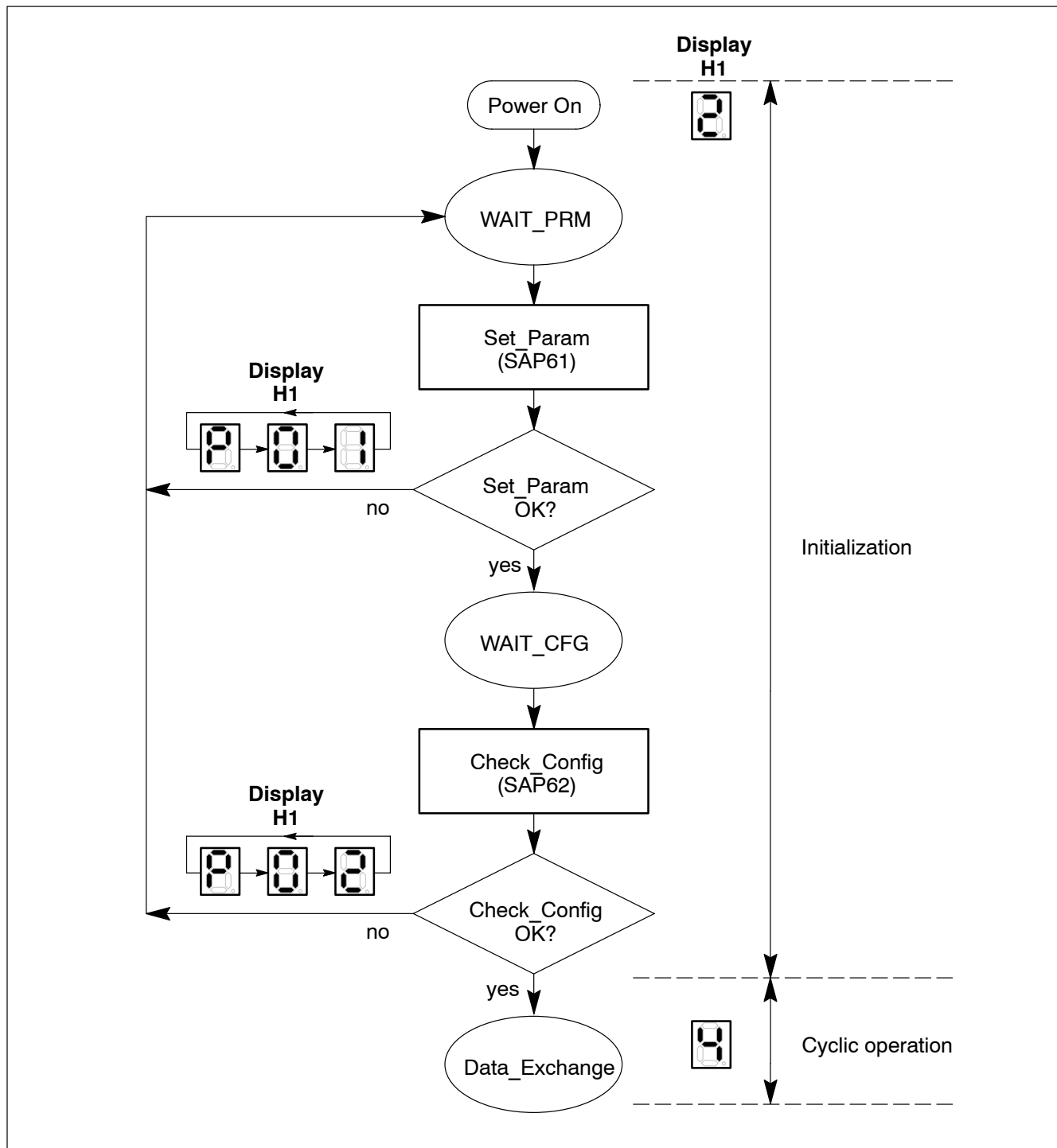

Set_Param (SAP61) transfers parameterization data to the slave. In addition to parameters applicable to the entire bus, this data also contains slave-specific information (e.g. drive operation mode) which has previously been stored in the master's parameter set.

For the structure of the parameterization data, refer to section 3.3.1.

Check_Config (SAP62) instructs the slave to verify the configuration data. In this case, the slave checks whether or not the actual configuration matches the desired configuration. For this purpose, the device type, format and length information as well as input and output data ranges (cyclic telegram structure) must be identical.

Next to the information to be exchanged in cyclic operation, the configuration data contain the scope of the input and output data areas as well as specifications for the consistency of the data.

For the structure of the configuration data, refer to section 3.3.2.

3.3.1 Structure of the parameterization data

Byte	Bit no.								Description	Type				
	MSB	7	6	5	4	3	2	1			0	LSB		
0	Lock Req	Unlo. Req	Sync Req	Free Req	WD on	Res	Res	Res	Station status		Standard			
1									WD_Fact_1	Standard				
2									WD_Fact_2			Standard		
3									MinTSDR				Standard	
4									Ident_Number_High					Standard
5									Ident_Number_Low					
6									Group_Ident		Standard			
7									Operating mode. Default setting: Interpolation in drive. 00H: Interpolation in drive (S-0-0032: 13H) 01H: Motion-controlled mode (S-0-0032: 23H) 02H: Velocity control (S-0-0032: 02H) 03H: Velocity control with actual value feedback (S-0-0032: 02H)	Bosch				
8									Reserved.			Bosch		

3.3.2 Structure of the configuration data

The configuration data determine the structure and allocation of the cyclic telegrams. All telegrams used later on are initialized accordingly by "identification bytes" sent by the master during the configuration phase to the DP slave.

Servodyn-D drives with a PROFIBUS-DP interface always expect to receive the identification bytes in the following order:

- Identification byte for the cyclic actual value telegrams and then
- Identification byte for the cyclic setpoint telegrams.

 **The configuration data and parameterization data must match each other!**

The selection of the desired drive mode (for parameterization data, refer to page 3-13; defined in the GSD file) always requires the definition of a suitable telegram configuration (by the configuration data).

The structure of the telegrams required for the individual drive modes is described in section 3.4 on page 3-16 ff.

MSB		Bit no.						LSB		Description
7	6	5	4	3	2	1	0			
									Length of data. 0000: 1 byte or word 0001: 2 bytes or words : 1111: 16 bytes or words	
									Input-output. 00: special identification formats 01: Input (telegram from slave to master) 10: Output (telegram from master to slave) 11: Input-output	
									Format length. 0: Byte (byte structure) 1: Word (word structure) When transmitting words, first the high byte and then the low byte is transmitted with PROFIBUS-DP. If "Word (word structure)" has been specified as format length, the master may exchange the bytes within the word if required by the target system.	
									Consistency through 0: Byte or word length 1: Total length	

Example: Identification byte = 60_H = 0110 0000_B

MSB		Bit no.						LSB		Description
7	6	5	4	3	2	1	0			
0	1	1	0	0	0	0	0		60 _H	
									Length of data. 0: 1 word (bit 6=1)	
									Input-output. 2: Output (telegram from master to slave)	
									Format length. 1: Word (word structure)	
									Consistency through 0: Word length	

Identification bytes: Motion-controlled mode (MC mode)

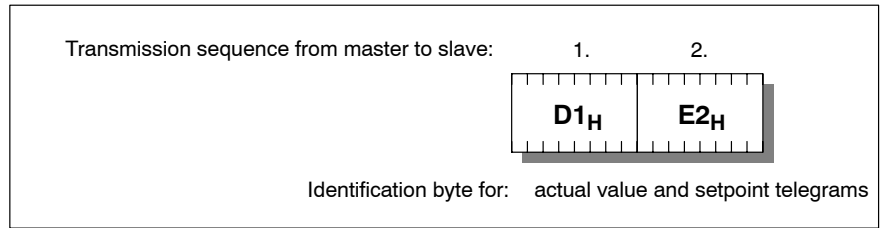

Identification bytes: Interpolation in drive

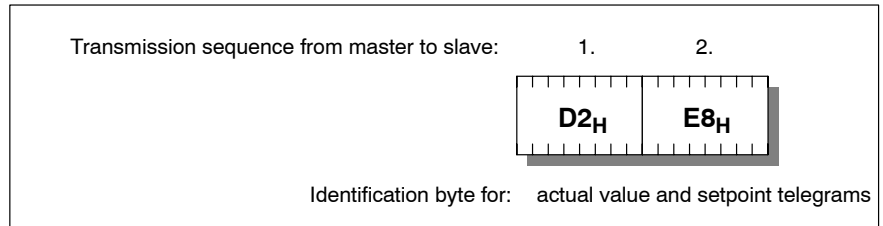

Identification bytes: Velocity control

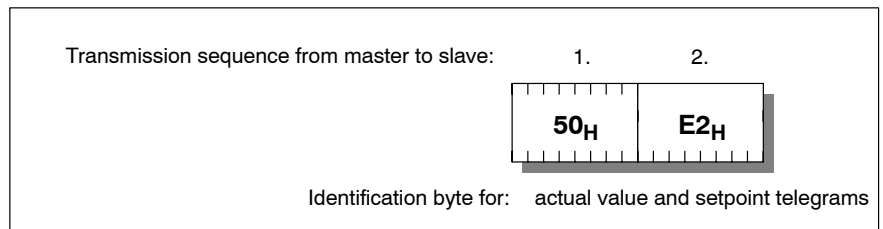

Identification bytes: Velocity control with actual value feedback

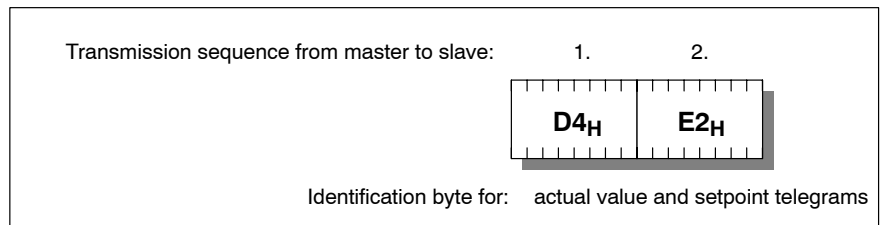

3.4 Cyclic operation

Following successful initialization, the PROFIBUS service

- Write_Read_Data/Data_Exchange (Default_SAP) ensures that data is exchanged between the master and the slave.

This process takes place in a fixed, repetitive sequence and is automatically initiated by the master. The master sends the "setpoint telegram" to the slave, and in return, it expects its "actual value telegram".

Display H1 on the inverter shows the value "4" in this condition.

- ☞ **You may display on the DSS the data that is exchanged:**
S-0-0024 (configuration list for master data telegram) contains the numbers of all parameters sent by the master to the slave.
S-0-0016 (configuration list for drive telegram) contains the numbers of all parameters sent by the slave to the master.

- ☞ **In the event of diagnostics messages or errors: refer to section 3.5 on page 3-18 ff.**

3.4.1 Telegram structure: Motion-controlled mode (MC mode)

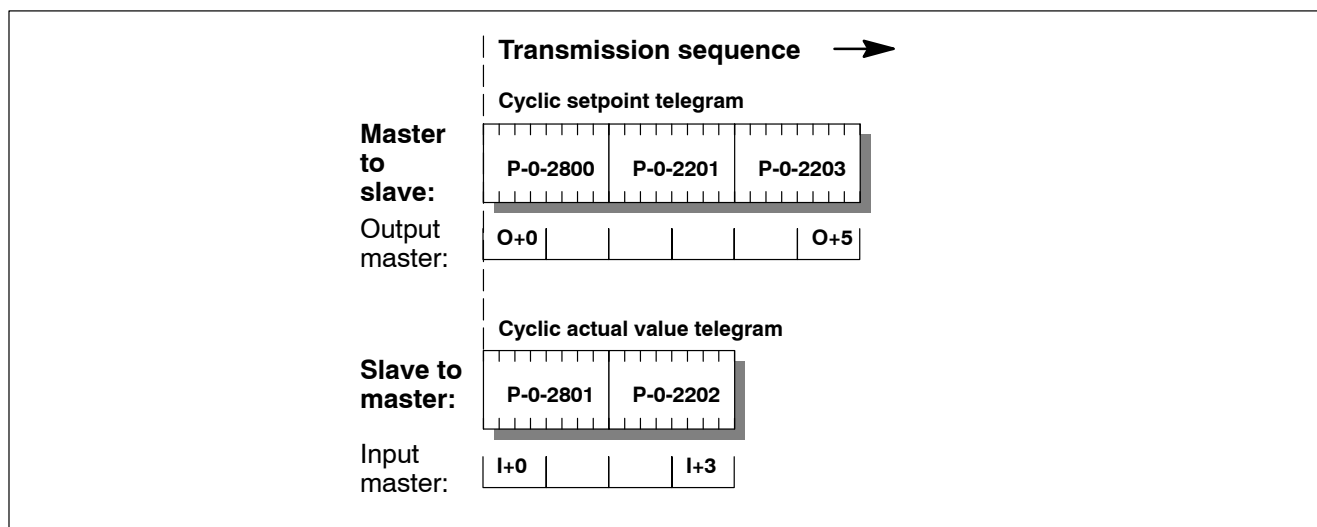

3.4.2 Telegram structure: Interpolation in drive

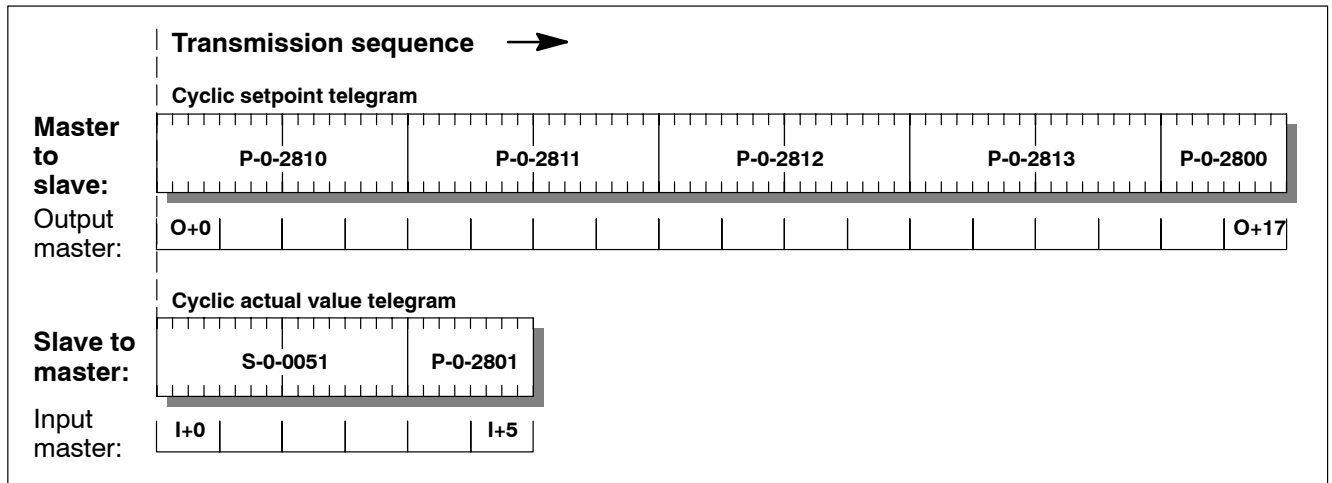

3.4.3 Telegram structure: Velocity control

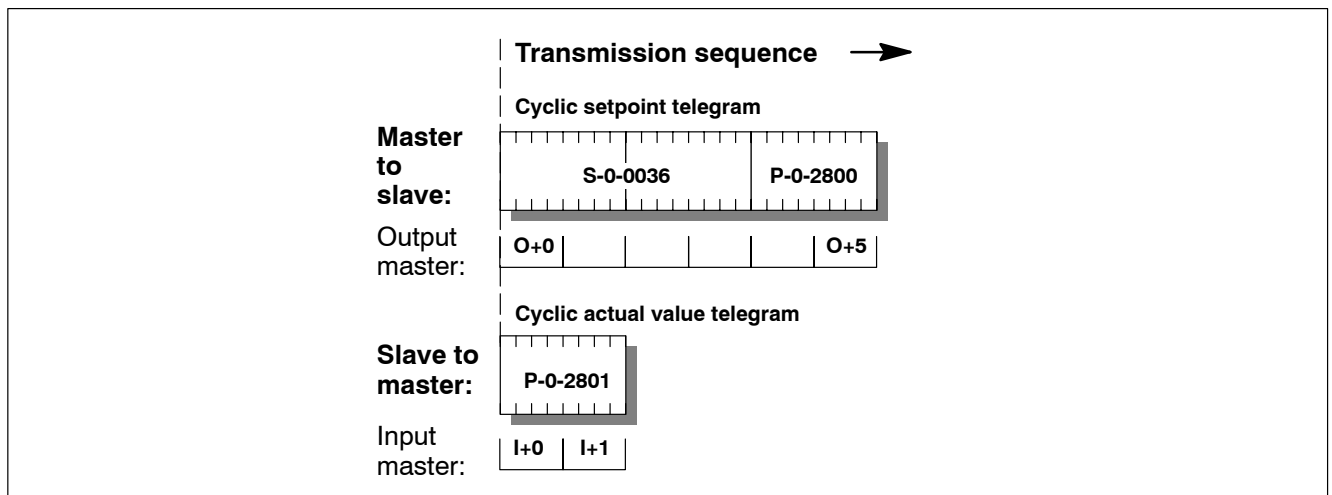

3.4.4 Telegram structure: Velocity control with actual value feedback

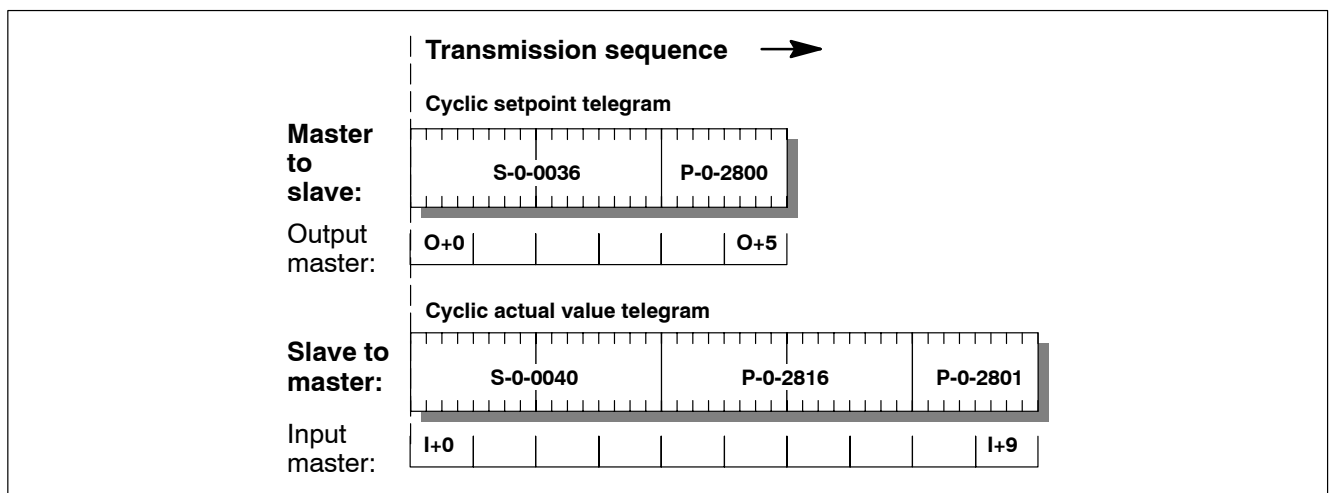

3.5 Diagnostics

If diagnostics messages or errors occur in cyclic operation (cf. page 3–16 ff), the slave sends a high-priority response telegram to the master (Slave_Diagnosis; SAP60).

The response telegram is comprised of

- standard diagnostics information (bytes 0 to 5) and, if necessary,
- extended diagnostics information (bytes 6 to 20; "Ext_diag_Data").

Extended diagnostics information will only be transmitted in the event of diagnostics class 1 errors. Each error is assigned exactly 1 bit. When an error is present, the corresponding bit is high.

The master can detect the presence of extended diagnostics information by the status of bit 3 of byte 0.

- Bit 3 of byte 0 is low: no extended diagnostics information
- Bit 3 of byte 0 is high: extended diagnostics information

If extended diagnostics information is present, byte 6 (header byte for device-specific diagnostics) contains more information about its structure.

Byte	Bit no.								Description	Type	
	MSB	7	6	5	4	3	2	1			LSB
0						X				Station status_1. Bit 3 = 0: no extended diagnostics information Bit 3 = 1: extended diagnostics information	Standard
1										Station status_2	
2										Station status_3	
3										Master address	
4										Ident. number: 014A (hex)	
5											
6	0	0	0	0	1	1	1	1		Header byte for device-specific diagnostics. Bits 0...5: Block length incl. header byte (000001 = 1 byte; ... ; 001111 = 15 bytes) Bits 6...7: identification	extended
7										Standard diagnostics class 1 (S-0-0011) Low byte	
8										High byte	
9										User1-diagnostics class 1 (S-0-0129) Low byte	
10										High byte	
11										User2-diagnostics class 1 (P-0-0493) Low byte	
12										High byte	
13										Hardware diagnostics class 1 Low byte	
14										High byte	
15										Encoder-diagnostics class 1 (P-0-0494) Low byte	
16										High byte	
17										CPU diagnostics class 1 Low byte	
18										High byte	
19										PROFIBUS (P-0-2803) Low byte	
20										High byte	

Structure of the response telegram

Possible diagnostics class 1 errors which are transmitted by the extended diagnostics information (Ext_Diag_Data):

Diagnostics class 1	Bit	Description	Indication
Standard	0	Overload trip	
	1	Amplifier overtemperature trip	F07
	2	Motor overtemperature trip	F08
	3	Cooling error trip	
	4	Control voltage error	F35
	5	Feedback error	F11
	6	Error in electrical commutation system	
	7	Overcurrent	F04
	8	Overvoltage	F30
	9	Undervoltage	
	10	Phase error of power supply	
	11	Excessive controller deviation	F13
	12	Communication error	F10
	13	Position limit has been exceeded	F14
	14		
15	Manufacturer-specific error		
User1	0	Speed controller synchronization error	
	1	Overspeed	F15
	2	Lag error	F12
	3	Current controller synchronization error	
	4	Analog-to-digital conversion error of current controller	
	5	VM error	F97
	6	VM tripped	F98
	7	Watchdog error	F06
	8	Option module error	
	9	Personality Module error	
	10	DSP program starts too early	F90
	11	SEC channel error	
	12	Speed monitoring error – hardware	
	13	Initialization error	
	14		
15	Motion Control Fatal Error	F80	
User2	0	Incorrect temperature sensor type, motor	F69
	1	Temperature measurement timeout	F69
	2	CPU time not sufficient	F06
	3	Life Guard Error	F10
	4		
	5		
	6		
	7		
	8		
	9		
	10		
	11		
	12		
	13		
	14		
15			

Diagnostics class 1	Bit	Description	Indication
Hardware	0		
	1		
	2	I ² C bus interface error	F60
	3	Initialization error: Driver identification	F71
	4	Initialization error: ADC-Init	F61
	5	Initialization error: Security	F65
	6	Initialization error: Overcurrent	F64
	7	Initialization error: PWM	F62
	8	Initialization error: Motor-module configuration	F72
	9	Initialization error: SERCOS tables	F63
	10		
	11		
	12		
	13	Error during RAM test	F51
	14	Error when writing parameters	F53
	15	Error when reading parameters	F54
Encoder	0	Encoder does not transmit absolute position	F70
	1	Parity error in absolute position	F70
	2	Error in zero point storage	F70
	3	Timeout when reading via SSI interface	F70
	4	Checksum error during data receipt	F70
	5	Timeout when writing via SSI interface	F70
	6	Number of encoder divisions not defined	F70
	7	I ² C bus initialization error	F70
	8	Error when reading via I ² C bus	F70
	9	Incorrect number of encoder divisions	F70
	10	Encoder parameter has the value 0	F70
	11	Timeout when reading via EnDat interface	F70
	12	Encoder interface not available	F70
	13	Error in EnDat data transmission	F70
	14	Error function of EnDat measuring system	F70
	15	Encoder not available	F70
CPU	0	Non-Maskable Interrupt	H01
	1	Stack Overflow	H02
	2	Stack Underflow	H03
	3	Undefined Opcode	H04
	4	Protected Instruction Fault	H05
	5	Illegal Word Operation Access	H06
	6	Illegal Instruction Access	H07
	7	Illegal External Bus Access	H08
	8	FP – Integer Overflow	H09
	9	FP – floating Overflow	H10
	10	FP – floating Underflow	H11
	11	FP – Divide by Zero	H12
	12	FP – undefined float	H13
	13	FP – Conversion Error	H14
	14	FP – floating point stack underflow	H15
	15	FP – floating point stack overflow	H16

Diagnostics class 1	Bit	Description	Indication
PROFIBUS	0	Initialization error: Profibus-PRM	P01
	1	Initialization error: Profibus-CFG	P02
	2		
	3		
	4		
	5		
	6		
	7		
	8		
	9		
	10		
	11		
	12		
	13		
	14		
	15		

Notes:

4 DSS user interface

4.1 DSS basic image

 The layout of the DSS user interface has been optimized for a screen resolution of 800 x 600 pixels in connection with a 15" color monitor. For reasons of ergonomics, you should not use screen resolutions of more than 800 x 600 pixels unless you have at least a 17" monitor.

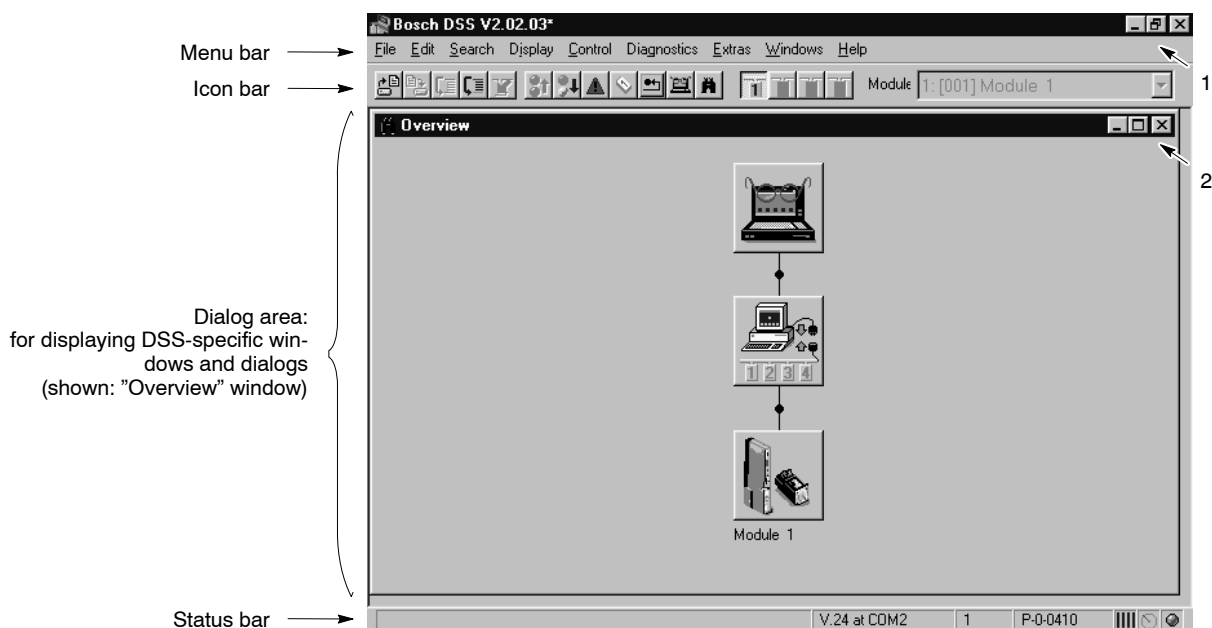

1 Changes the DSS program window and exits the program.

2 Changes a DSS-specific window

Please note that iconized window symbols may be covered by open win-
dows. Covered windows can be displayed by selecting the "Windows"
menu.

Icon bar

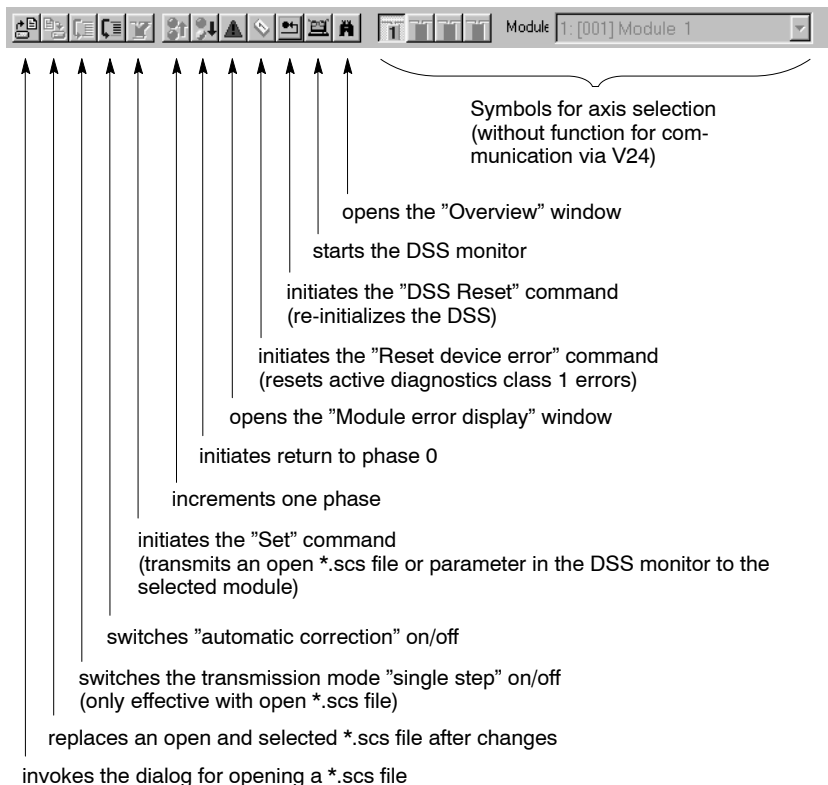

When the mouse pointer is placed on a symbol, its function is shown for a moment in plain text.
Recessed symbols signal the status "function activated".

Status line

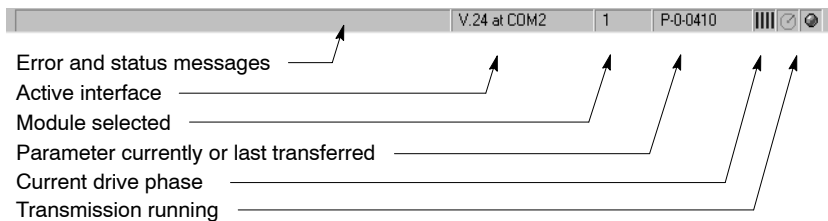

"Overview" window

The "Overview" window shows a schematic diagram of all communication components of the system on the basis of individual command buttons:

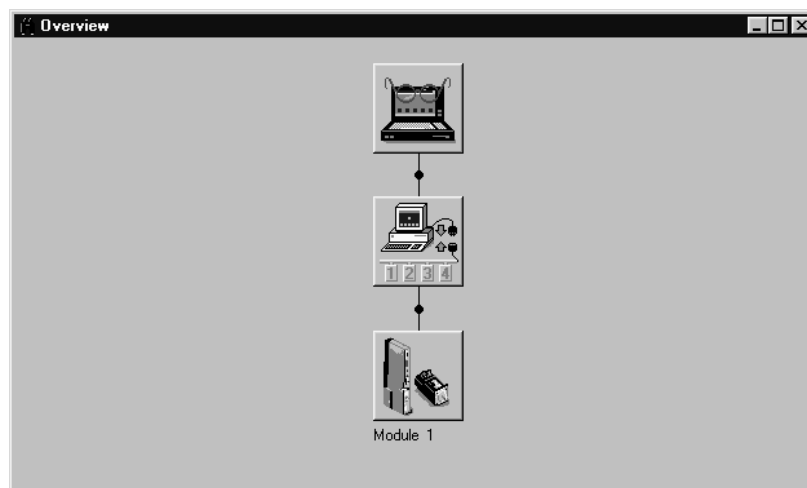

Command buttons in the "Overview" window

Each command button represents a communication component of the system. Communication components may include not only modules connected, but also internal program sections of the DSS by which the communication between the module and the DSS is influenced.

 **When the mouse pointer is placed on a command button, the function/name of this button is shown briefly.**

By clicking on a command button, the DSS starts

- the related program section immediately (e.g. oscilloscope), or
- displays a pulldown menu from which component-specific commands/functions can be called up.



(Parameterization)



- Monitor (edit parameters on-line)
- Load file (edit parameters off-line)
- DSS expert



(Motion control, no function with PROFIBUS-DP interface)



(Setpoint input)



- Setpoint box
- Setpoint generator



(Interface)



- Increment/Reset phase
- Select interface
- DSS Reset
- Cyclic telegram



(Module x)



- Reset device error
- Load/Save main memory
- OpMode selection
- Module status display
- Module configuration
- Starts the DSS monitor with predefined parameter lists for controller, amplifier, motor or encoder

 **Whether or not certain command buttons are available depends on the currently active user group (refer to page 4-11).**

4.2 DSS monitor

The DSS monitor offers direct **Online access** to all parameters stored in the drive.

You may:

- edit parameters
- save a list of several parameters as initialization file (*.scs) of the drive. For each drive, several *.scs files can be created, e.g. for certain drive functions or commissioning steps
- transmit imported *.scs files to the drive (cf. page 4-7)

☞ **Whether or not several instances of the DSS monitor can be started, can be configured by selecting the "Open DSS monitor only once" checkbox on the "Global" tab of the EXTRAS ► PREFERENCES menu.**

★ Start the Monitor by

- the menu sequence DISPLAY ► MONITOR – or –
- Icon bar: Click on



– or –

-  ► MONITOR in the "Overview" window.

Annotations:

- Name of parameter in plain text (cannot be changed):** Points to the 'Name' field.
- Current **changeable** parameter number:** Points to the 'Ident No.' field.
- Current **changeable** parameter value. When the "Data" text appears dimmed, the data cannot be changed.** Points to the 'Data' field.
- Input limits of the current parameter:** Points to the 'Range' field.
- Parameter list. Double-click on one of the parameters to display its information in the upper fields.** Points to the parameter list table.
- Read current parameter from the drive:** Points to the 'Update...' button.
- Transfer current parameter to the drive. Parameter change becomes immediately active.** Points to the 'Get' button.
- Read all parameters of a *.scs file and display them in a list.** Points to the 'Import' button.
- Save all parameters in the list as *.scs file.** Points to the 'Export' button.

Table:

Module	IDN	Name	Value	Unit
This field contains all parameters that have been read or imported at least once since the last monitor call.				

Single parameter

1. Click on the "Ident. no" field
2. Enter the parameter number to be edited.
The following syntax options may be used:
 - complete, e.g. "S-0-0040" or "P-0-0100"
 - simplified, e.g. "s40" or "p100"
 - only the number, e.g. "40" instead of "S-0-0040" (factory setting).

 **The way in which the DSS monitor is to interpret an omitted ident. number prefix (S-, P-, C-, etc.) can be configured by selecting the "Automatic Ident No" checkbox on the "Global" tab of the EXTRAS ► PREFERENCES menu.**

3. Press <RETURN> or click on the "Get" button to read the parameter from the drive.

If the parameter has not been defined in the drive, a fault message will be displayed.

4. Modified parameters can be transferred back to the drive with "Set" where they will become immediately active.

For this purpose, the drive must be switched to a phase in which the current parameter can be changed. Please refer to the "Changeable" field in the attributes bar shown in the "Servodyn-D parameter description" manual for this information.

For changing phases, refer to section 4.6.1, page 4–12.

 **Once they have been transferred, the parameters will remain active only until you switch off the drive or press the RESET button on the module.**

If the parameters should be permanently active in the drive, you have to perform the "Save main memory" command (page 4–13).

All parameters that have been read will be automatically entered in the parameter list and sorted according to their ident. numbers. A parameter list can be saved in a *.scs file using the "Export" function.

 **To delete parameters from the list: click on the list line in question and press key.**

Parameter lists

By clicking on the "Import" command button, all **parameters of a *.scs file** are imported to the parameter list of the DSS monitor.

 **The import process will delete all existing list entries! Use the "Export" command button to save the current list entries beforehand.**

It is also possible to open **standard parameter lists**. Standard parameter lists contain the ident numbers of predefined **thematic areas**:

- Controllers (speed, position or current)
- Amplifier
- Motor or
- Encoder.

A standard parameter list in the DSS monitor cannot be supplemented by additional ident numbers because the "Ident no" field cannot be edited in this case.

For this type of lists, the DSS always creates an additional instance of the DSS monitor with the name of the selected thematic area (e.g. "Motor").



Opening the standard parameter list: Click on  in the "Overview" window and select the desired thematic area.

Current parameter

Current **changeable** parameter value. When the "Data" text appears dimmed, the data cannot be changed.

Input limits of the current parameter

List of all parameters of the subject area in ascending order. Double-click on one of the parameters to display its information in the upper fields.

Module	IDN	Name	Value	Unit
1	S-0-0109	Motor Peak Current	19199	mA
1	S-0-0111	Motor Current at Sta...	4799	mA
1	S-0-0113	Maximum Motor Spe...	3600.0000	RPM
1	S-0-0141	Motor Type	SF-A3.0068.030	
1	S-0-0196	Motor Nominal Current	4799	mA
1	S-0-0201	Motor Temperature ...	145.0	°C
1	S-0-0204	Motor Shutdown Te...	155.0	°C
1	S-0-0312	Motor Dvertemperat...	0b0000.0000.0000.0...	
1	P-0-0016	Motor Temperature	20.9	°C
1	P-0-0200	Temperature Motorpr...	0.0	

If active: Clicking on "Get" command button will read **all** parameters of the list from the drive.

Transfer current parameter to the drive. Parameter change becomes immediately active.

Save all parameters in the list as *.scs file.

1. To edit the parameters, double-click on the desired parameter in the list. It will then be accepted to the upper fields as current value.

Whether or not the DSS is to read the parameter again from the module can be configured by selecting the "Reload with double click" checkbox on the "Global" tab of the EXTRAS ► PREFERENCES menu.

To read all parameters in the list again, mark the "All ID no's" checkbox and confirm by clicking on "Get".

2. When they have been changed, the parameters can be transferred back to the drive individually with "Set" where they will become immediately active if the drive has been switched to the appropriate phase (cf. above).

Transmitting complete parameter list to the drive

To transfer a complete parameter list to the drive, you first have to save the list in a *.scs file (cf. above).

Then, this file can be transmitted to the drive (cf. section 4.3 on page 4-7 ff.).

4.3 Editing/sending *.scs files

*.scs files can be edited and saved in the integrated editor (offline parameterization).

If *.scs files have been loaded into the editor, the complete files may be transmitted to the drive.

1. Select the desired *.scs file by
 - the menu sequence FILE ► OPEN, or
 - Icon bar: Click on



– or –

-  ► DSS FILE in the "Overview" window.

2. Load the selected *.scs file into the editor by clicking on "Open".
Several files may be opened in parallel. Each file will then be displayed in a separate editor window.
3. Edit the file.

 **For more information on the structure and syntax of *.scs files, please refer to the DSS help system which you may call up with HELP ► CONTENTS in the "DSS files" paragraph of the "Syntax" chapter.**

 **It is also possible to combine several *.scs files with the "INCLUDE" command. When contained in a *.scs file, the "INCLUDE" command will cause the contents of a specified file to be sent instead of the line containing INCLUDE when the file is transmitted to the drive. For more information on the syntax and possible commands in *.scs files, please refer to the DSS help system which you may call up with HELP ► CONTENTS in the "DSS files" paragraph of the "Syntax" chapter.**

4. When data has been changed, you may save the file by
 - the menu sequence FILE ► SAVE, or
 - Icon bar: Click on



 **The previous file will be completely overwritten. If this is not desirable, you have to save the file under a different name. In this case, you should select the menu sequence FILE ► SAVE AS...**

5. To transmit the file in the **active editor window** to the drive, select
 - the menu sequence EDIT ► SET, or
 - Icon bar: Click on



After transmission, the 7-segment display on the module shows the value "4". Now the drive uses this data.

In connection with file transmission, the following functions may be used:

Single step:

The displayed file is loaded to the drive's RAM **line by line**. Before a line is transmitted, the DSS expects a confirmation.

The "Single step" function can be activated/deactivated by

- the menu sequence EDIT ► SINGLE STEP, or
- Icon bar: Click on



Single step is active: The symbol is shown "recessed".

Automatic correction:

Ident. numbers rejected by the drive with the error message "currently write-protected" will be transmitted again after the next phase change-over contained in the file.

The "Automatic correction" function can be activated/deactivated by

- the EDIT ► AUTOMATIC CORRECTION, or
- Icon bar: Click on



Automatic correction is active: The symbol is shown "recessed".

4.4 Selecting the language

The DSS user interface and the parameter and diagnostics texts from the drive have to be changed over separately in order to obtain a uniform language representation in the DSS.

Language of user interface

- ★ Select the "Display" tab from the EXTRAS ► PREFERENCES menu:

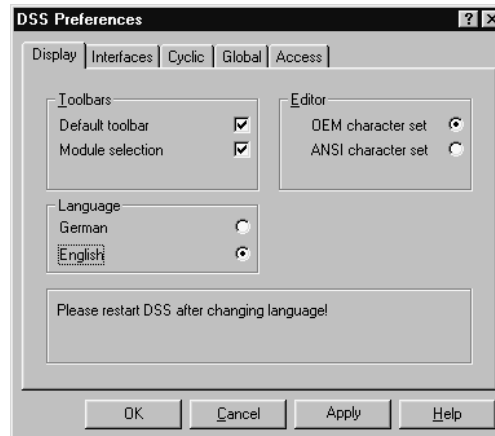

- ★ Select the desired language and hit the "Apply" command button to confirm your selection. To activate the new language, you have to restart the DSS.

Language of the drive

The language of the parameter/diagnostics texts in the drive is defined in parameter S-0-0265. The languages listed in S-0-0266 may be selected:

- 0 : German
- 1 : English.



- ★ Enter the numerical value of the desired language in the "Data" field. Pressing <Return> or clicking on "Set" will immediately change over the language. This becomes obvious by the text in the "Name:" field.

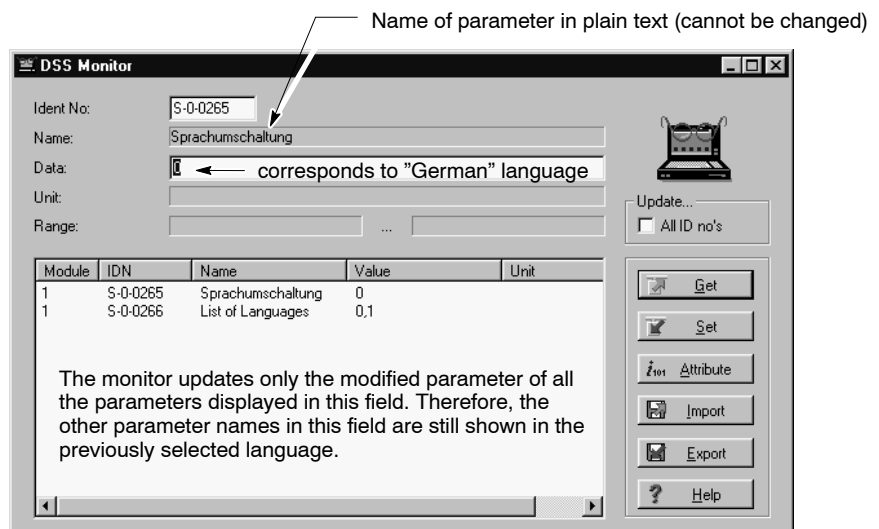

The new setting will only remain active until you switch off the drive or press the RESET button on the inverter.

To switch the drive permanently to the new language, you have to perform the "Save main memory" command (cf. page 4-13).

4.5 Changing the user group (password)

The DSS makes a distinction between different user groups in order to protect several program functions against unauthorized interventions:

Function	User group (category)		
	Customer (always active after program start)	Service Level 1	Service Level 2
Standard functions	•	•	•
Predefined parameter lists on special issues		•	•

The "Service" user group is password-protected. The corresponding passwords are available on request.

- ★ Select: EXTRAS ► PREFERENCES ► "Access" tab.



CAUTION

Unauthorized access to protected functions possible!
If you have changed the user group to "Service" you should complete the necessary operations and restart the DSS or reset the system to the "Customer" group (password: koenig).
Otherwise, anyone may access all protected functions until the DSS program is exited.

4.6 Important drive commands

4.6.1 Changing phases

 You have to use the DSS to change over to phases 0 to 4. When booting, the drive only needs phases 2 and 4 (cf. page 3-12).

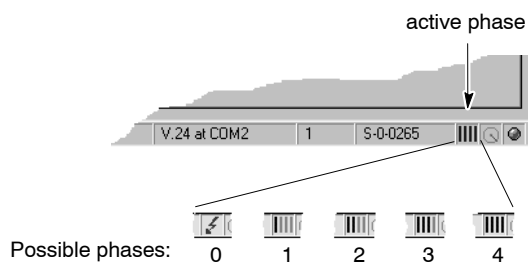

Various parameters can only be changed in certain initialization phases. Therefore, during commissioning, you first have to switch the drive to the required phase before changing such parameters. If you forget changing phases, an error message of the type "Data of parameter x-0-xxxx is write protected at this time!" will usually be output.

You may change to the **higher next phase** by:

- Menu sequence CONTROL ► INCREMENT INITIALIZATION PHASE – or –
- Icon bar: Click on



– or –

-  ► INCREMENT INITIALIZATION PHASE in the "Overview" window.

You may **change back to phase 0** by

- Menu sequence CONTROL ► DECREMENT INITIALIZATION PHASE – or –
- Icon bar: Click on



– or –

-  ► DECREMENT INITIALIZATION PHASE in the "Overview" window.

4.6.2 Save main memory

When switched on, or if the "RESET" button has been depressed, the inverter first copies all data contained in the FEPRAM to the RAM and uses the RAM data for operation only. Changing parameters will initially affect the RAM data only. In order to give a lasting effect to parameter changes, you therefore have to execute the "Save main memory" command before switching off or a RESET. By issuing this command, the drive will copy the data from the RAM to the FEPRAM.

 **The "Save main memory" command is no alternative for a backup! For example, parameters that have been set and optimized during initial commissioning can be used for another drive only (series commissioning), if a backup was made (refer to section 5.3 on page 5-10).**



CAUTION

"Save main memory" cannot be reversed!

All data contained in the FEPRAM will be replaced with the current data.

If you are not sure whether you still need the old FEPRAM data, please contact your systems administrator before executing this command.



CAUTION

Current operating mode will also be saved!

Exit the active setpoint box, if any, or the setpoint generator before triggering "Save main memory". Otherwise, the setpoint inputs by the PROFIBUS will not take effect!

- ★ Switch the drive to phase 4.
- ★ Select the menu sequence
 - CONTROL ► SAVE MAIN MEMORY
 - or –
 -  ► SAVE MAIN MEMORY in the "Overview" window.

4.6.3 Load main memory

This command loads all data stored in the FEPRAM to the drive's RAM. When switched on, or if the "RESET" button at the inverter has been depressed, the drive automatically copies all data contained in the FEPRAM to the RAM.



CAUTION

The main memory of the drive is overwritten!

All data in the RAM will be replaced with the parameters contained in the FEPRAM by the "Load main memory" command. This process cannot be reversed.

If you are not sure whether you still need the old RAM data, please contact your systems administrator before executing this command.

- ★ Switch the drive to phase 2.
- ★ Select the menu sequence
 - CONTROL ► LOAD MAIN MEMORY
– or –
 -  ► LOAD MAIN MEMORY in the "Overview" window.

4.6.4 Resetting errors (class 1)

If errors of diagnostics class 1 have occurred, the drive will be interlocked (optimum shut-down with subsequent torque removal).

- ★ In order to unlock the drive when the error has been eliminated,
 - set bit 3 in the PROFIBUS control word P-0-2800, or
 - reset the error in the DSS.

To reset the error in the DSS, open the logbook for diagnostics class 1 errors (cf. section 8.1). The error history is listed by the error codes in the logbook. Alternatively, open the "Module error display" by

- menu sequence DIAGNOSTICS ► MODULE ERROR DISPLAY, – or –
- Icon bar: Click on



Locate the cause of the error and eliminate all errors. Then, enter the command "Reset device error" by

- Menu sequence CONTROL ► RESET DEVICE ERROR, – or –
- Icon bar: Click on



– or –

-  ► RESET DEVICE ERROR in the "Overview" window.

Notes:

5 Initial commissioning

- ★ Make sure that all of the hardware checks described in section 2 have been properly carried out.
- ★ **Backup** the factory settings currently stored in the FEPRM. Afterwards, you may restore the original status of all values whenever you like.
Select the menu sequence:
FILE ► IDN BACKUP
Enter a file name for the original data, e.g. "ORG_PAR.SCS". The drive is switched to phase 4, then reads all parameters stored in the FEPRM and saves them in the previously specified file.

5.1 Setting of basic parameters

The factory settings of the drive parameters have been selected so as to enable you to drive the motor **for test purposes** without changing the parameters.

In order to adjust the drive exactly to your application, a few basic parameters have to be changed.
The parameters of other functions described in section 5.2 can be set according to need.

The following parameter numbers are of relevance for the basic parameter setting:

 **For a detailed description of the following parameters, please refer to the "Servodyn-D parameter manual"**

Functionality	Relevant parameters	Default value	Your value
<p>Operating frequency of the power output stage: A low operating frequency increases the available electrical output power. It must be set according to the selected motor/module combination: 4 or 8 kHz. Changes do not become active unless the power supply and 24 VDC supply have been switched off and on!</p>	<p>P-0-0001 Operating frequency of the power output stage (changeable in phase 2/3/4)</p>	8000 Hz	
<p>Maximum speed limit value: Maximum speed in both directions of rotation. If the setpoint is higher than the value entered in this parameter, the drive will set the message $n_{set} > n_{limit}$ (S-0-0013, bit 5).</p>	<p>S-0-0091 Bipolar velocity limit value (changeable in phase 3/4)</p>	2000 rpm (weighting iaw S-0-0044)	
<p>Maximum torque limit value: Maximum admissible torque, symmetrical for both directions.</p>	<p>S-0-0092 Bipolar torque limit value (changeable in phase 3/4)</p>	300 % (weighting iaw S-0-0086)	

Functionality	Relevant parameters	Default value	Your value
Maximum acceleration: Maximum acceleration capacity, symmetrical for both directions.	S-0-0138 Acceleration bipolar (changeable in phase 3/4)	3000 rad/s ² (weighting iaw S-0-0160)	
Behavior after "Drive off" or a fault: You may choose between: <ul style="list-style-type: none"> • "Halting in shortest possible time" (S-0-0138) • "Halting with ramp" (S-0-0260) • ""Setpoint-controlled halting by master" The torque will remain active for the duration of the "Waiting time drive off" (S-0-0207).	P-0-0004 Halting mode with drive off (changeable in phase 2)	0b0000.0000.0000.0000 (= in shortest possible time)	
Behavior after removal of the external drive enable signal: You may choose between: <ul style="list-style-type: none"> • "Halting without setpoint control" • "Effect depends on P-0-0004" (the torque will remain active for the duration of the "Waiting time drive off" (S-0-0207)). 	P-0-0125 Control word ext. Enable (changeable in phase 2)	0b0000.0000.0000.0000 (= effect depends on P-0-0004)	
Holding brake: "Waiting time drive on" accounts for the time required for releasing the brake, thus preventing excessive wear: <ul style="list-style-type: none"> • The "Drive on" and "Drive enable" signals will first activate the torque, depending on P-0-0505 (Plug brake enable delay). • The drive will not follow the setpoint input before the "Waiting time drive on" has elapsed. "Waiting time drive off" prevents the axis from jerking caused by the removal of the torque while the holding brake has not yet engaged.	S-0-0206 Waiting time drive on (changeable in phase 3/4) S-0-0207 Waiting time drive off (changeable in phase 3/4)	0 ms 0 ms	
Plug braking: When the "Drive on" and "Drive enable" signals have been set, the torque will not become active unless P-0-0505 has elapsed. This is to prevent that the motor power is connected although the braking resistors are still active on the motor line because of hardware-related delays when deactivating the braking resistors.	P-0-0505 KSB enable delay (changeable in phase 2/3/4)	0 ms	

- ★ Select EXTRAS ► INITIALIZATION GUIDE.
 The initialization guide will lead you step-by-step through the basic parameter setting process.
 Once the individual steps have been passed, you may send the basic parameter settings directly to the drive.
 If necessary, the data may be additionally saved in a *.scs file.

Alternatively, you may use the monitor instead of the initialization guide in order to adapt all values to your needs and transmit them to the drive.

- ☞ **Please note that the current drive phase may have to be changed before a parameter can be adjusted in the monitor (for changing phases, refer to page 4–12).**

- ★ You should now test whether the movement behavior of the drive and the signal sequence meet your requirements.
If this is the case, please execute the "Save main memory" command (cf. section 4.6.2).
Otherwise, adjust your basic parameter setting accordingly.
- ☞ **Without "Save main memory", the modified parameters will only remain active until you switch off the drive or press the RESET button on the inverter.**

- ★ For data protection, you should now save all EPROM parameters in a *.scs file using the "IDN Backup" function.

The default directory used for data backups can generally be changed in the "Global" tab of the EXTRAS ► PREFERENCES menu:

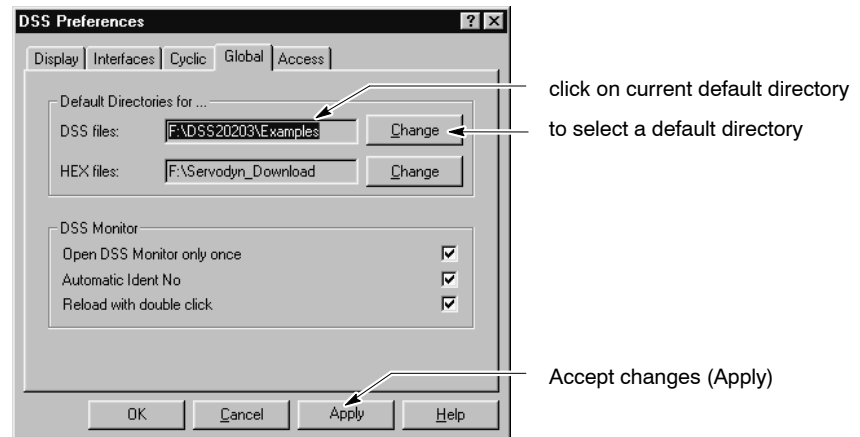

5.2 Enhanced programming

5.2.1 Initializing absolute encoders

 **This function can only be performed for motors equipped with multi-turn encoders (rating plate information on encoder: EQN 1325).**

- ★ Load P-0-0006 (Position encoder type – motor encoder) into the monitor and set the value to 1 (= absolute encoder function active).
In this case, the software supports you with the determination of the absolute dimension offset (S-0-0177).
- ★ Turn the power supply of the drive on. Enable the drive with a zero setpoint. The drive is stopped, the torque is active.
- ★ Move the axis to the mechanical zero position.
- ★ Select
EXTRAS ► DRIVE FUNCTIONS ► INIT ABSOLUTE ENCODER.

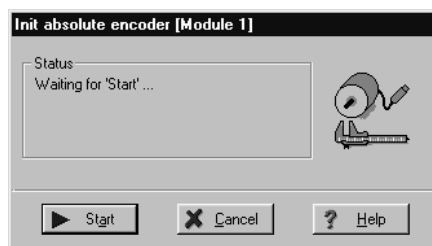

- ★ Click on "Start"

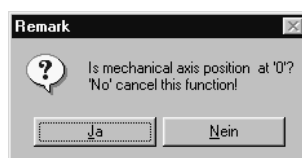

- ★ Click on "No" to abort the function.
Clicking on "Yes" will start the measurement.
After the measurement, the system will display the current offset:

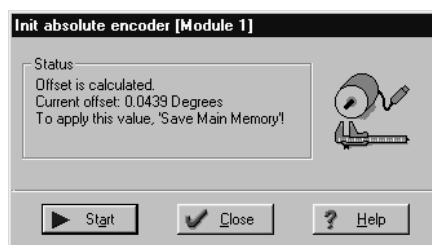

- ★ Close the dialog.
- ★ Execute the "Save main memory" command (cf. section 4.6.2).
- ★ Reboot the drive.

5.2.2 Digital inputs and outputs (IN x, OUT x)

For connecting external I/O peripherals,

- 4 digital inputs (IN1 to IN4) and
 - 4 digital outputs (OUT1 to OUT4)
- are available at the drive.

 **The digital I/Os require a power supply to X06. For technical data of the inputs and outputs, refer to "Interface conditions" manual.**

The parameters which may be assigned to the outputs are shown by the "D → M" entry in the "Real-time bit" column of the attributes bar in the "Parameter description" manual.

Parameters that may be changed via an input are marked by the "M → D" entry in the "Real-time bit" column of the attributes bar.

 **Outputs OUT2 to OUT4 cannot be influenced! They are permanently assigned to the following functions:**

OUT2: Temperature warning
OUT3: Control of a holding brake
OUT4: Control of a plug braking process

- ★ In order to set the parameters of the digital inputs or outputs, switch the drive to phase 2.
- ★ Load parameters P-0-2000 (inputs) and P-0-2002 (outputs) into the monitor.
- ★ Assign a list containing the desired parameter numbers to the value of P-0-2000 and P-0-2002. The order of the parameter numbers is used to specify which parameter corresponds to which input/output. Separate the individual parameter numbers by commas.
- ★ When designing the list in P-0-2002 (outputs), please note the following assignments:

- Parameters can be set for output
- Output is permanently assigned. No parameters can be set

OUT1	OUT2	OUT3	OUT4
------	------	------	------

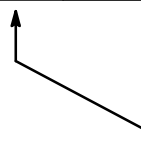

P-0-2002=<1 . Par>

- ★ When designing the list in P-0-2000 (inputs), please note the following assignments:

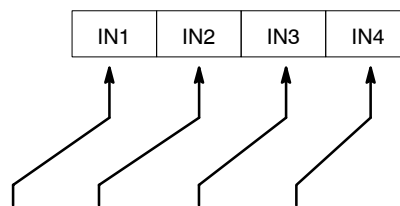

P-0-2000=<1 . Par>,<2 . Par>,<3 . Par>,<4 . Par>

- ☞ **Gaps in the signal configuration should be filled with S-0-0000.**

Example 1:

If only IN3 is to be assigned, program P-0-2000 as follows:

P-0-2000=0,0,<Par . >

- ★ Execute the "Save main memory" command (cf. section 4.6.2).

5.2.3 Torque monitoring

Every drive is equipped with 2 monitoring features each of which can be configured independently.

Every monitoring feature compares the current torque value with its specific limit values and stores the result of the comparison in a separate parameter. Since both parameters have been implemented as real-time bits (signal status bits), one of them can be assigned to the hardware output OUT1 of the drive and evaluated, e.g. by the PLC.

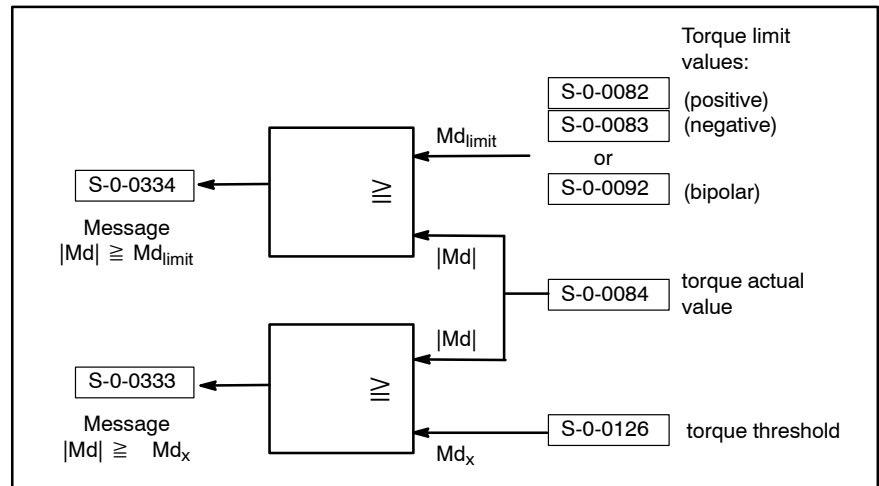

If one of the monitoring features responds (= contents of S-0-0333 or S-0-0334 becomes HIGH), the drive internally responds by setting certain bits in parameter S-0-0013 (diagnostics class 3).

Further reactions (such as reduction of torque or speed, retract movements, EMERGENCY-STOP) have to be initiated externally by the higher-level control unit!

- ★ Adjust the limit values for torque monitoring to your requirements.
- ★ Assign parameters S-0-0333 or S-0-0334 to hardware output OUT1 of the drive in order to provide for evaluation (cf. page 5-5).
- ★ Execute the "Save main memory" command.

5.2.4 Weighting and data reference

The weighting and data reference specify:

- the internal calculation by the drive
- the units of measure to be used for the axis
- whether velocity data is referred to the motor shaft or the axis
- the units of measure in which the analog signals of the OM4 option module are output

Default settings

 The following default settings normally do not have to be changed.

Weighting:	rotational			
Unit of measure:	Position data	S-0-0076	Degrees	Bits 0...4 have to be identical
	Velocities	S-0-0044	rpm	
	Acceleration	S-0-0160	rad/sec	
	Torque/force data	S-0-0086	%	
Data reference:	to the motor shaft			

```
S-0-0076= 0b00000000000000010 ; [] Type of weighting for position data
S-0-0044= 0b00000000000000010 ; [] Type of weighting for velocity data
S-0-0160= 0b00000000000000010 ; [] Type of weighting for acceleration data
S-0-0086= 0b00000000000000000 ; [] Type of weighting for torque/force data
```

Translational weighting

When linear axes are used, you have to adjust the standard settings:

- ★ Set weighting to "translational"
(bits 0 to 2 in S-0-0044, S-0-0076 and S-0-0160)
- ★ Set data reference to "at the load"
(bit 6 in S-0-0044, S-0-0076 and S-0-0160)
- ★ Specify the input and output speeds of an interconnected gearbox, if any.
Only integers are permitted here.

Example:

The transmission ratio is Ratio = 1 : 128.18

First, you have to eliminate the decimal places:

→ Ratio = 100 : 12818 (by multiplication with 100), or

→ Ratio = 50 : 6409 (by multiplication with 50)

Enter calculated values in S-0-0121 and S-0-0122 :

→ S-0-0121 = 100; S-0-0122 = 12818, or

→ S-0-0121 = 50; S-0-0122 = 6409

- ★ Specify feedrate constant by which the rotational motor movement is converted into a translational axis movement.

Default:

no gearbox (S-0-0121 = 1; S-0-0122 = 1)

Feedrate constant of 1 mm/rev.

```
S-0-0121= 1 ; [input rev.] Load gear box input revolutions
S-0-0122= 1 ; [output rev.] Load gear box output revolutions
S-0-0123= 1.0000 ; [mm/rev] Feedrate constant
```

- ★ Check the values of the following parameters:
 - S-x-0091: Bipolar velocity limit value
 - S-x-0092: Bipolar torque limit value
 - S-0-0138: Acceleration bipolar

5.2.5 Option OM4: Analog outputs

The OM4 option board provides additional analog measuring outputs. Thus, current values of max. 2 parameters can be converted simultaneously to analog linear output signals of 0...+10 V and evaluated externally (e.g. by means of a storage oscilloscope for control unit optimization).



CAUTION

**Error message "F06" or undefined drive behavior through excessive processor load with OM4 possible if all outputs are used!
Do not use more than 2 measuring outputs at a time. The high-speed outputs 3 and 4 may be used simultaneously.**

Parameter values that have been assigned to outputs 1 and 2 are read in 1 ms cycles.
Parameter values that have been assigned to outputs 3 and 4 are read in 0.5 ms cycles.
Each output converts the respective parameter value via a linear characteristic into a 0...+10 V analog voltage.

- ★ Select:
EXTRAS ► DRIVE FUNCTIONS ► ANALOG I/O ► ANALOG OUTPUTS

"IDN" fields (P-0-2010): determine the parameter value to be output at the corresponding output

"Max. value" fields (P-0-2012 to P-0-2015): define for which value +10 V are output

"Offset" fields (P-0-2012 to P-0-2015): define for which value 0V are output

- ★ Adjust the individual fields to your requirements. Modified values will be immediately transmitted to and activated in the connected drive when the field is exited (e.g. with the <Tab> key). If this is not desired, you have to cancel the dialog before leaving a field by clicking on "X" in the title bar.

- ★ Close the dialog and perform the "Save main memory" command.

For more information on the parameters outlined above, please refer to the "Servodyn-D parameter manual".

5.3 Save all parameter settings (data backup)

It is urgently recommended to backup all relevant data when the parameters for a drive have been set.

This data backup will be required to

- efficiently perform series commissioning
- restore a precisely defined drive status (e.g. after a parameter loss, firmware update or hardware replacement)
- document all parameters used for a drive.

- ★ Make sure that **no** drive enable command has been given.
 - ★ Select the menu sequence:
FILE ► IDN BACKUP
Enter a new file name. The drive is switched to phase 4, then reads all parameters stored in the FEPRM and saves them in the previously specified file. An exception are driver files and the data of the electronic rating plate.
 - ★ Create a suitable directory structure on the hard disk drive of your PC to which you can copy all parameter files of the drive.
For example, you could establish a hierarchy that adequately represents individual machine types including their feed, auxiliary and spindle axes.
 - ★ Copy all files to a removable data carrier. Store this data carrier in a safe place.
-  **In order to transfer the backup back to the drive, if necessary, load the file into the DSS editor, click on the "Automatic" radio button and then select "Set" (cf. section 4.3).**

6 Series commissioning

During series commissioning, all data backed up from the FEPRM after initial commissioning of a drive are loaded to and saved in all other drives.

 **If your application involves drives with different settings, initial commissioning has to be performed separately for every single setting.**

- ★ Make sure that all works described in section 2.1 and 2.2 have been properly executed for each drive to be commissioned.
- ★ Establish communication between the first drive to be commissioned and the DSS (cf. section 2.3).

6.1 Loading files

- ★ Make sure that all required *.scs files are available for the drive currently connected to the DSS. These may be *.scs files
 - generated when setting the basic parameters (cf. page 5–1 ff.)
 - generated when programming the extended parameters (cf. page 5–4 ff.)
 - generated during controller optimization (cf. page 7–2 ff.)
- ★ If you have created *.scs files for the individual commissioning steps using the "IDN Backup" function, you only have to transfer the *.scs file that was created last (because "IDN backup" always saves **all** parameters contained in the FEPRM).

If you saved parameters "one by one" in *.scs files during commissioning, you should transmit the files to the drive in the same order in which they were created:

1. Select the desired *.scs file by

- the menu sequence FILE ► OPEN – or –
- Icon bar: Click on



– or –

-  ► DSS FILE in the "Overview" window.

2. Load the selected ".scs file into the editor by clicking on "Open".

 **Several files may be opened in parallel. Each file will then be displayed in a separate editor window.**

3. To transmit the file in the **active editor window** to the drive, select
 - the menu sequence EDIT ► SET, or
 - Icon bar: Click on



After transmission, the 7-segment display on the module shows the value "4". Now the drive uses this data.

4. Close the active editor window and transmit the remaining *.scs files, if any.

6.2 Couple next drive

- ★ Remove the connection line from X99 and plug it to X99 of the next axis module to be commissioned.
- ★ Reinitialize the DSS:
 - menu
CONTROL ► DSS RESET, – or –
 - Icon bar: Click on



7 Test and optimization

7.1 Optimizing the control unit

As a rule, the drive performance is satisfactory when the basic parameters and the additional parameters have been set, i.e. it is not necessary to make more adjustments at the control unit.

If necessary, however, the speed controller and the filter can be modified within the servo system.

☞ In order to visualize the effects of optimization on the control loop, a storage oscilloscope and the OM4 option module with suitably parameterized measuring outputs (cf. section 5.2.5, page 5–9) are absolutely necessary.



CAUTION

Any interventions in the parameters of the control units are reserved to persons with profound knowledge of the individual control unit parameters and experience in the optimization of servo loops!

The following block diagram is designed to give you an overview of the parameters of the servo loop:

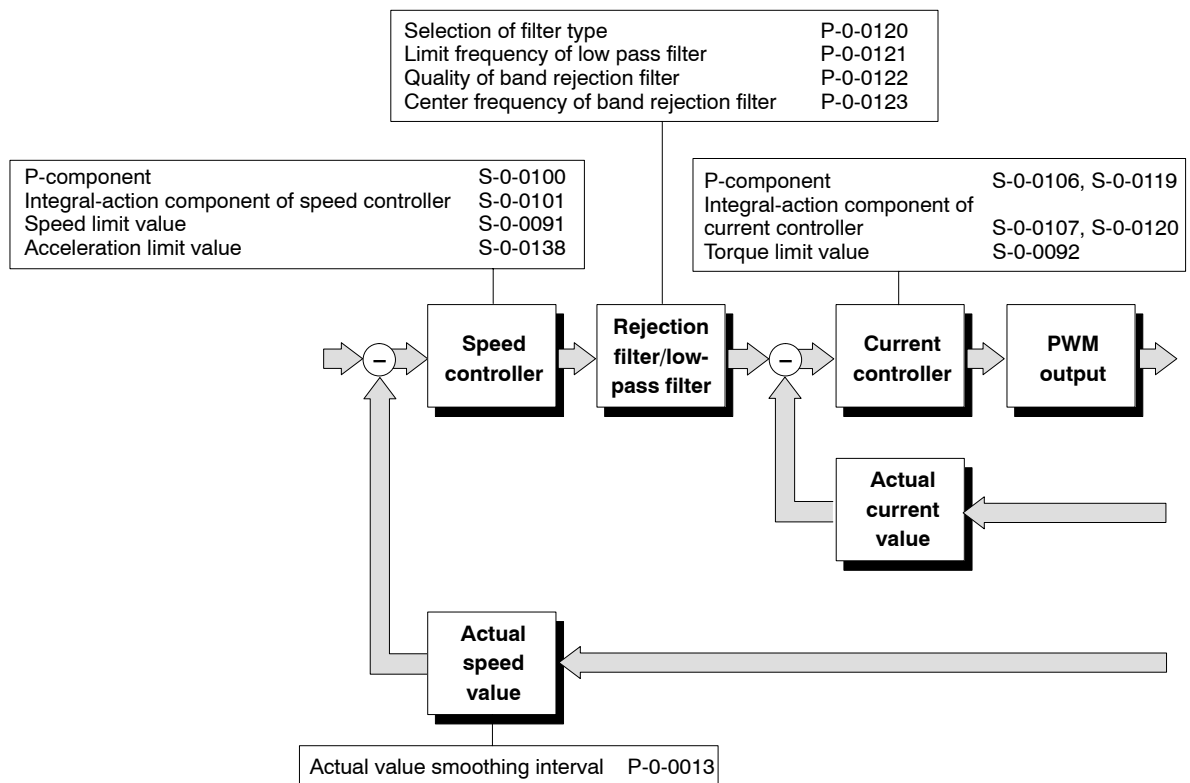

☞ The parameters of the current controller are critical for the drive behavior. They must not be changed without having consulted Bosch.

7.1.1 Optimization steps

- ★ You should not optimize any settings unless the load is connected and the position control loop is open ("Velocity control" drive mode).
- ★ Specify a velocity of $v=0$ in the PROFIBUS master and turn on the drive's power supply. Enable the drive. The drive follows the setpoint input. The torque is active.
- ★ Start with the default value of S-0-0100 (approx. "50").

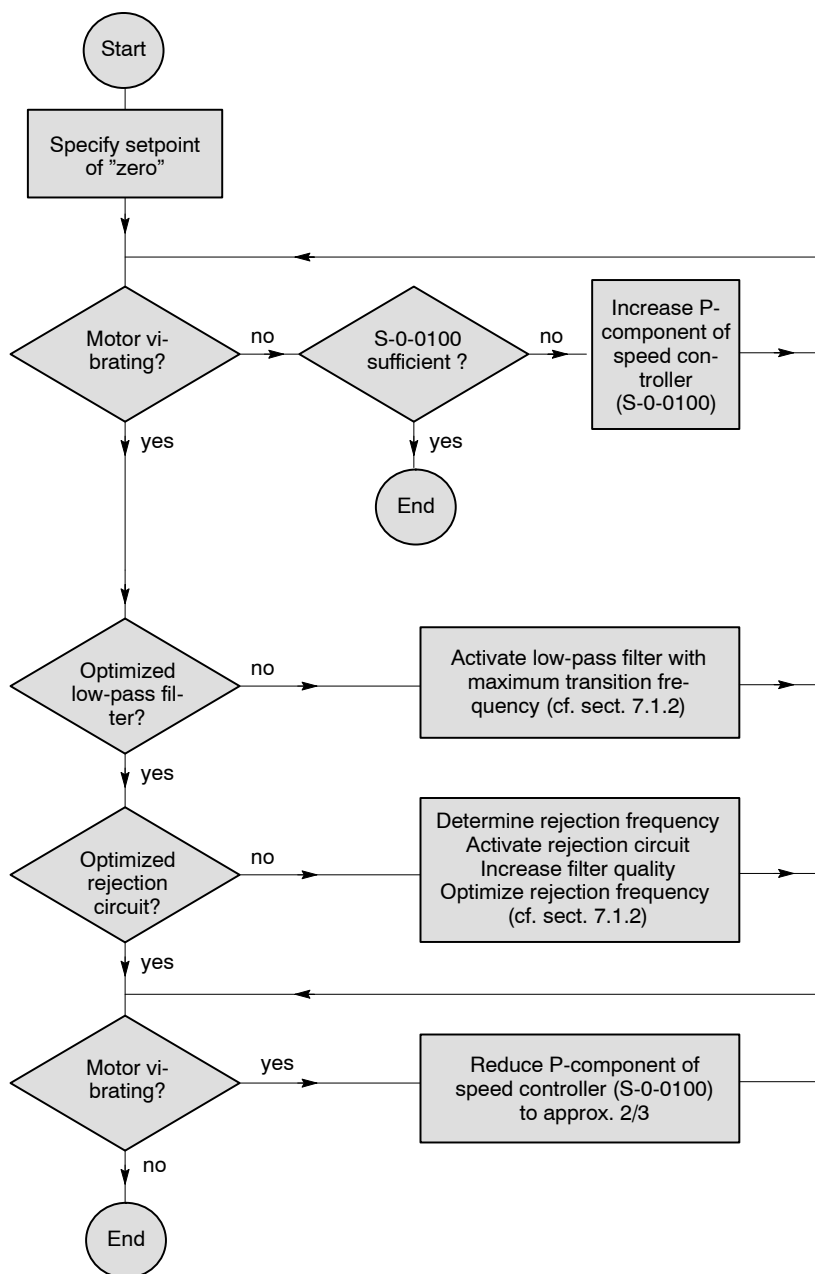

- ★ Execute the "Save main memory" command (cf. page 4–13).
- ★ Select FILE ► IDN BACKUP
Enter a new file name. The drive is switched to phase 4, then reads all parameters stored in the FEPR0M and saves them in the previously specified file. An exception are driver files and the data of the electronic rating plate.

7.1.2 DSS tools

- ★ In order to change the parameters, you should use the "Speed controller" and "Band stop filter" thematic areas of the DSS expert. Select: EXTRAS ► DSS EXPERT

The current parameter setting will now be read from the drive for all thematic areas of the DSS expert. Wait until this process has been completed. The drive is now in phase 2.

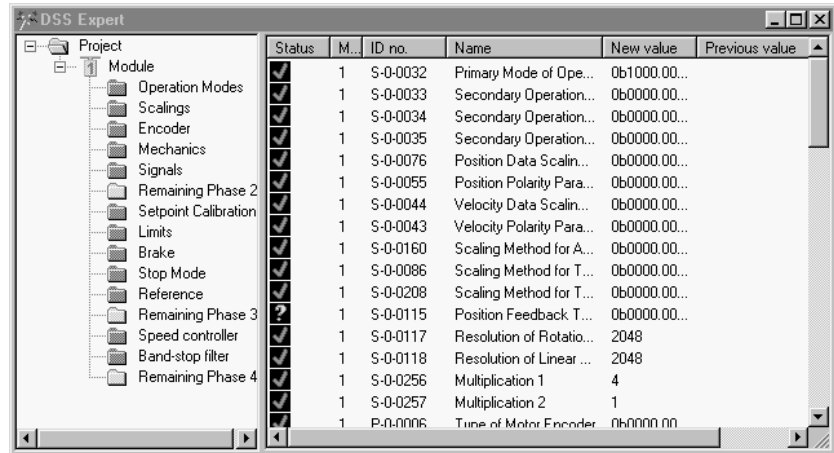

- ★ In order to process the parameters of the "Speed controller" and "Band stop filter" thematic areas, click on the area in question and select EDIT from the pop-up menu.

Detailed information speed controller

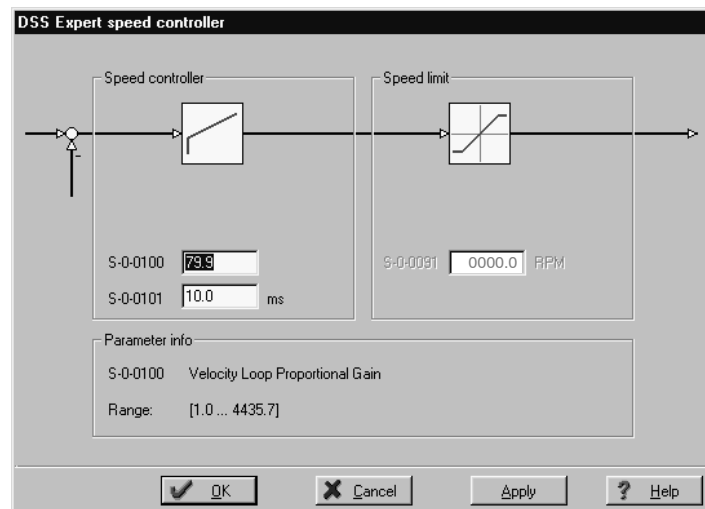

- ★ Double click on the input field to be modified, and enter the desired values. The "Parameter info" field now shows the parameter name and the admissible input range.

Apply: transfers the current values to the drive. They will become immediately active. The drive is now in phase 4.
 OK: as "Apply". The dialog is closed.

Status	M..	ID no.	Name	New value	Previous value
?	1	S-0-0052	Actual Position Feed...	0.0000	
?	1	S-0-0054	Actual Position Feed...	0.0000	
?	1	S-0-0150	Reference Offset 1	0.0000	
?	1	S-0-0151	Reference Offset 2	0.0000	
✓	1	S-0-0177	Absolute Dimension ...	-48.5595	
?	1	S-0-0178	Absolute Dimension ...	0.0000	
?	1	S-0-0165	Distance Coded Ref...	0	
?	1	S-0-0166			
?	1	S-0-0407			
?	1	P-0-0031	Absolute Rotation Of...		
✓	1	S-0-0100	Velocity Loop Propor...	79.9	49.9
✓	1	S-0-0101	Velocity Loop Integra...	10.0	10.0
✓	1	P-0-0120	Current Command Fil...	0,0,0,0	
✓	1	P-0-0121	Current Command Fil...	2000,0,20...	
✓	1	P-0-0122	Current Command Fil...	1,0,1,0,1,0...	
✓	1	P-0-0123	Current Command Fil...	2000,0,20...	

Parameters belonging to a thematic area that had previously been selected will be shown with a grey background. Parameter changes can be recognized by the "New value" and "Previous value" columns.

Detailed information band stop filter

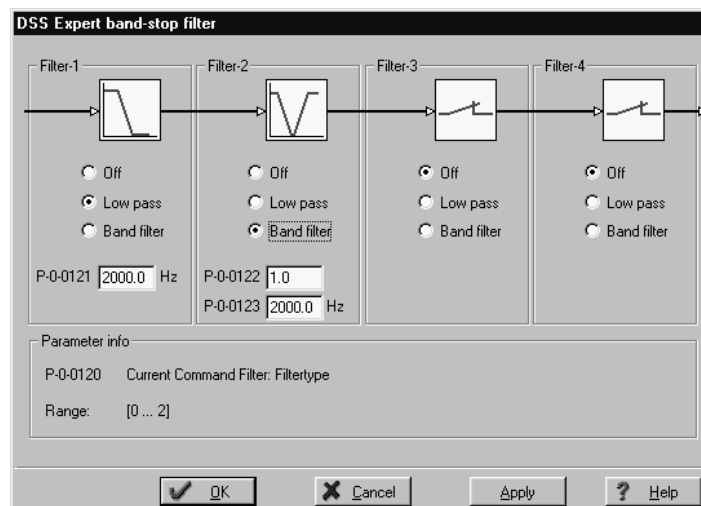

Up to 4 filters connected in series can be activated. Depending on the selected filter type, input fields are displayed for configuration.

- ★ Click on the radio buttons in order to define the filter type or deactivate individual filters.
- ★ Double click on the input field to be modified, and enter the desired values. The "Parameter info" field now shows the parameter name and the admissible input range.

Apply: transfers the current values to the drive. They will become immediately active. The drive is now in phase 4.

OK: as "Apply". The dialog is closed.

8 Diagnostics

8.1 Drive configuration / logbook

You will be shown **static** information on:

- software version (firmware version)
 - module and motor type
 - current DSS mode (in the "DSS Master" area)
 - application
 - interface type and version
 - DSS errors
 - Diagnostics class 1 errors
- ★ Start the configuration display with
- menu options DIAGNOSTICS ► MODULE CONFIGURATION, – or –
 -  ► MODULE CONFIGURATION in the "Overview" window.
- ★ Do not perform any operations (mouse click, keyboard entry, etc.) before the module configuration display appears. The DSS will only read the necessary information from the drive when the module configuration display is called up.

Example of the configuration display for a drive with an analog interface:

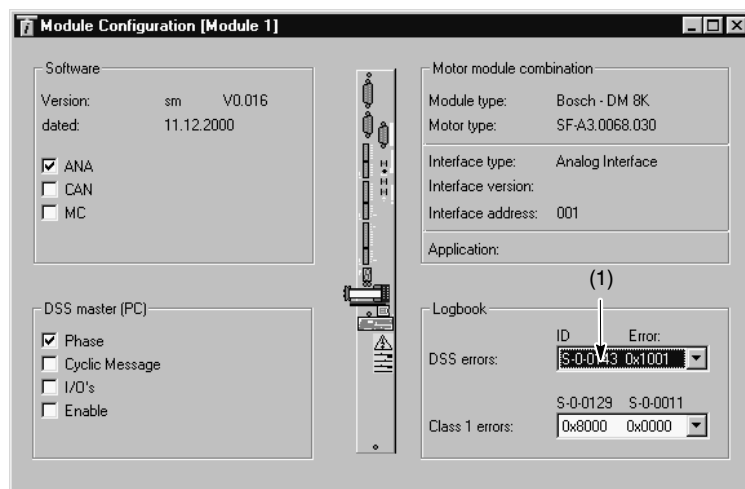

Logbook

In the "Logbook" area, you may display the last 16 "DSS errors" and "Class 1 errors" at any time.

DSS errors: communication errors between the DSS and the drive. The error list contains the parameter number that experienced the error during transmission, as well as the corresponding error code. To display the error in plain text, click on (1) and then press <F1>.

Class 1 errors: Contents of parameter S-0-0129 (Manufacturer's Class 1) and S-0-0011 (Diagnostics class-1) are shown as hexadecimal values. Every high bit is assigned a certain error (cf. "Servodyn-D parameter description" manual).

8.2 Drive status

The display will show **dynamic** information on

- drive status: diagnostics message in plain text
- values of max. 4 selectable parameters
- condition of the 4 least significant bits of parameter P-0-2003
- status of "Drive ON", "Drive enable", and "Drive start"
- current operation mode
- changes in "diagnostics class 1" to "diagnostics class 3" parameters (S-0-0011 to S-0-0013)

Displaying cyclic data

★ Select the menu sequence:

- DIAGNOSTICS ► MODULE STATUS DISPLAY, – or –



- ► MODULE STATUS DISPLAY in the "Overview" window.

Drive status in plain text as per S-0-0095.

Display of max. 4 parameters. For configuration, cf. page 8-3.

For displaying parameters in separate windows, refer to section 8.4 page 8-5.

Display of 4 digital outputs (P-0-2003).

For configuration, cf. P-0-2002 and section 5.2.2, page 5-5. Also refer to section 8.3.

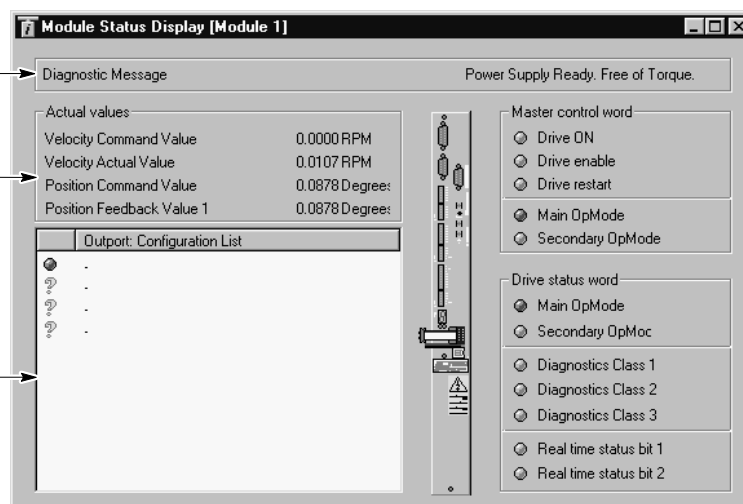

For updating frequency of the data, refer to page 8-3.

Configuring cyclic data

You may influence:

- the cycle time (time base for transmitting messages to the drive),
- the refresh rate of screen displays, and
- the contents of the cyclic display in the "Actual values" area of the module status display

- ★ Select the menu sequence
EXTRAS ► PREFERENCES ► "Cyclic" tab.

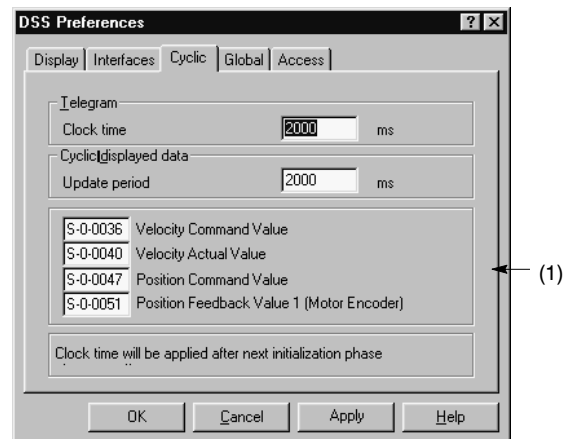

- ★ Enter the parameter number to be cyclically displayed in area (1). Although you may enter any available parameter in the fields, only those parameters make sense whose value changes with time.



CAUTION

The PC may respond very slowly to user activities!

Times that have been selected too short in the "Update period" field may lead to a very slow response, especially if slow computers are used.

You should not use times of less than 2000 ms unless particularly frequent updates of the display are absolutely necessary.

- ★ Hitting "Apply" will immediately activate all changes, "OK" will furthermore close the dialog.

- ☞ **For a cyclic display of parameters in different windows, refer to page 8-5.**

8.3 I/O signals

The DSS shows you

- the signals assigned to the digital inputs and outputs of the module, and
- the current status of these signals.

For the assignment of individual signals to the digital inputs and outputs of the module, please refer to section 5.2.2 on page 5-5 ff.

- ★ Select the menu sequence DIAGNOSTICS ► I/O SIGNALS.

Example of a display for a drive with an analog interface:

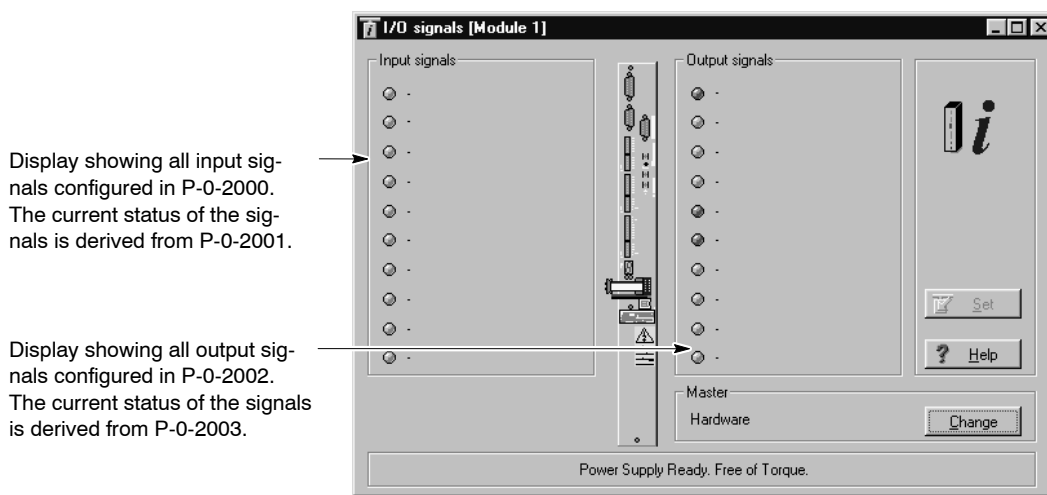

A HIGH level is indicated by a **green** LED, a LOW level by a **gray** LED by the DSS.

LEDs not followed by a text indicate that the corresponding bit has not been assigned to a signal in P-0-2001.

The data display is updated in the intervals set for the "Module status display" (cf. page 8-3).

8.4 Separate window for cyclic display

The DSS can display any parameters dynamically in separate windows. In addition to a pure text format, you may also choose a progress bar for display.

- ★ Select the menu sequence DIAGNOSES ► WATCH IDN.
- ★ Enter the parameter to be displayed in the "Ident no." field and a description in the "Comment" field, if necessary.
- ★ Select "Value" or "Progress bar" as View type. When "Progress bar" has been selected, the desired upper and lower limit may be specified for calibration purposes.

Display as value ...

The screenshot shows the 'Watch IDN' dialog box. The 'Ident no.' field contains 'S-0-0040'. The 'Velocity Actual Value' parameter is selected. The 'Comment' field contains 'test'. The 'View type' dropdown is set to 'Value'. The 'Range' field is empty. At the bottom, there are 'OK', 'Cancel', and 'Help' buttons.

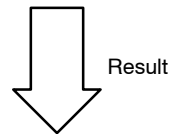

The screenshot shows a separate window titled 'Velocity Actual Value'. It displays the text 'test [RPM]' followed by the numerical value '999.8498'.

Display as value and as progress bar ...

The screenshot shows the 'Watch IDN' dialog box. The 'Ident no.' field contains 'S-0-0040'. The 'Velocity Actual Value' parameter is selected. The 'Comment' field contains 'test'. The 'View type' dropdown is set to 'Progress bar'. The 'Range' field contains '0' and '2000'. At the bottom, there are 'OK', 'Cancel', and 'Help' buttons.

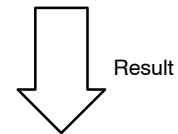

The screenshot shows a separate window titled 'Velocity Actual Value'. It displays the text 'test [RPM]' followed by the numerical value '1000.6563'. Below the text is a progress bar that is approximately half-filled.

- ★ Clicking on "OK" will close the DSS dialog and display the parameter cyclically in a separate window.

The data display is updated in the intervals set for the "Module status display" (cf. page 8-3).

- ☞ **Parameter values (e.g. setpoints and/or actual values) can also be output via analog outputs (cf. section 5.2.5). Thus, it is possible to visualize the drive responses, e.g., using a storage oscilloscope.**

8.5 Updating the parameter values of a *.scs file

An existing *.scs file can be taken as a basis for a template file in which the parameter values are replaced with current values and then saved in a new file. In terms of function, this process can be compared to "filling in" a template.

The system will not add any additional parameters to the target file or change the sequence of the parameters stored.

This function can be used to

- document the parameters of a drive (e.g. by printing an OEM-specific updated template file containing all parameters used)
- find out the differences between parameters of different drives.

- ★ First, you should create a complete *.scs file as a template and save this file. When "filling in" this template, the system will only consider the values of the parameters contained in the template.
- ★ Select the menu sequence FILE ► FILL & TEMPLATE.

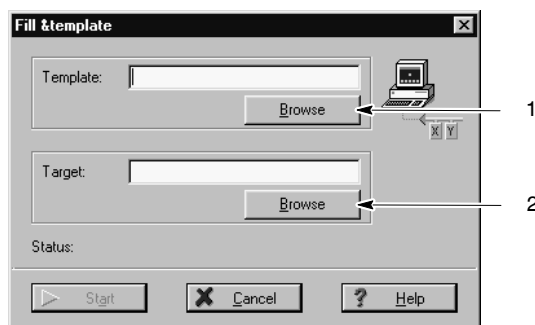

- ★ Click on "1" in order to select the template file. Only the parameters contained in this file will be read from the drive.
- ★ Click on "2" to enter the path and name of the target file.

☞ Please note that the contents of an existing target file will be completely replaced by "filling-in" the template!

- ★ Click on "Start" to generate the target file. When the message "Operation successful completed" is displayed in the status line, you may close the dialog.

A Annex

A.1 Pin assignment of the PROFIBUS-DP interface (X51)

Cannon connector, 9-pole.
 Type: RS-485; Field bus interface to EN 50170 Part 2 (DP)
 Cable length: depending on transmission rate used
 Cable type: screened, min. core cross-section 0.14 mm²
 Transmission rate: automatic detection, max. 12 Mbit/s

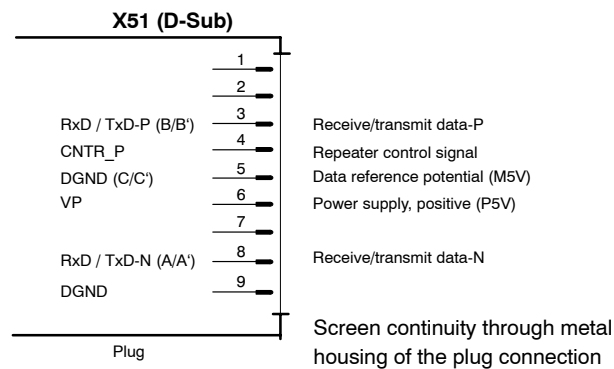

A.2 Pin assignment of the RS232 interface at the drive (X99)

Cannon connector, 9-pole.
 Type: RS232
 Cable length: max. 15 m
 Cable type: screened, min. core cross-section 0.14 mm²
 Transmission rate: 9600 bit/s
 Parameters: even parity, 8 data bits, 2 stop bits
 Handshake: software handshake (X_{ON}, X_{OFF})

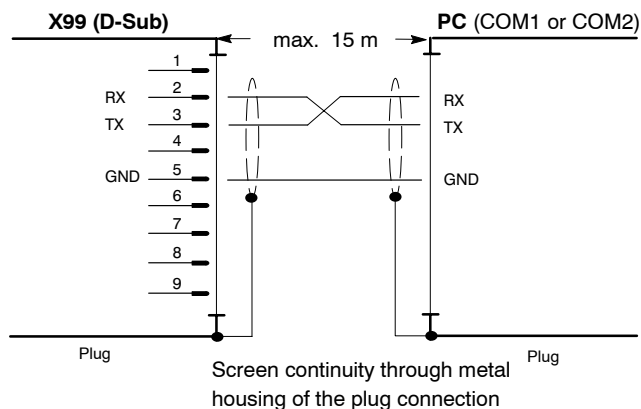

Assignment:
 RX Receive Data
 TX Transmit Data; data transmission to DSS
 GND Signal Ground

A.3 Index

- A**
 Analog measuring outputs, 5–9
 Analog output of parameter values, 5–9
- B**
 Backup, 5–10
 Band stop, 7–4
 Band stop configuration, 7–4
 Booting of drive, 3–12
- C**
 Changing phases, 4–12
 Checking the hardware, 2–2
 Commissioning, Series, 6–1
 Communication, between the drive and DSS, 2–5
 Configuration of inputs, 5–5
 Configuration of outputs, 5–5
 Connection, DSS at the drive, 2–5
 Cyclic operation, 3–16
- D**
 Default directory, 5–3
 Diagnostics, 3–18, 8–1
 Diagnostics class 1 errors, 3–19, 8–1
 Display H1, 3–12
 Displaying data, cyclic, 8–2
 in separate window, 8–5
 parameter definition, 8–3
 updating frequency, 8–3
 Displaying I/O signals, 8–4
 Documentation, 1–7
 Documenting the parameters of a drive, 8–6
 Drive
 Display configuration, 8–1
 Displaying the status, 8–2
 ON, Enable, Start, 8–2
 DSS, initialize, 2–6
 DSS errors, 8–1
 DSS monitor, 4–4
- E**
 EMC Directive, 1–1
 EMC product standard, 1–1
 EMERGENCY–STOP circuit, Check functioning, 2–3
 EMERGENCY–STOP devices, 1–5
 Errors
 Diagnostics class 1, 8–1
 DSS, 8–1
 resetting, 4–15
 ESD
 Electrostatic discharge, 1–6
 grounding, 1–6
 workplace, 1–6
 ESD–sensitive components, 1–6
 Establish connection, Drive–DSS, 2–5
 Exit the DSS program, 4–1
- F**
 Feedrate constant, 5–8
 FEPROM
 Backup, 5–10, 7–2
 copy to the RAM, 4–14
 Filling in a template, 8–6
 Filter configuration, 7–4
 Firmware version, 8–1
 Floppy disk drive, 1–7
- G**
 Gear box, 5–8
 Grounding bracelet, 1–6
- H**
 Hard disk drive, 1–7
 Holding brake
 Check control logic, 2–3
 Controlling via OUT3, 5–5
- I**
 Identification bytes, 3–14
 IDN backup, 5–10, 7–2
 Initialization, 3–12
 Initialization file, transmit to drive, 6–1
 Initializing, DSS, 2–6
 Initializing absolute encoders, 5–4
 Inport, 5–5
 Intended use, 1–1
 Interface
 disconnect connection cable, 2–6
 setting parameters for RS–232, 2–5
 X51, 2–4
 X99, 2–5
 Interpolation in drive, 3–5
- K**
 KSB, Controlling via OUT4, 5–5
- L**
 Logbooks, 8–1
 Low pass, 7–4
 Low–Voltage Directive, 1–1
- M**
 Machinery directive, 1–1
 Main memory
 load, 4–14
 save, 4–13
 Mechanics, 5–8
 Modes
 interpolation in drive, 3–5
 Motion–controlled mode, 3–2
 Velocity control, 3–8
 Velocity control with actual value feedback, 3–10
 Modifications, 1–8
 Module change, 2–6
 Module configuration display, 8–1

Module status display, 8–2
Module type, 8–1
Modules sensitive to electrostatic discharge. See ESD–
sensitive components
Motion–controlled mode, 3–2
Motor type, 8–1

O

Offline, 2–6
OM4 optional module, 5–9
Optimization, 7–1
Optimizing the control unit, 7–1
Outport, 5–5

P

Parameter lists, transmitting to the drive, 4–6
Parameters, display cyclically, 8–5
Password, 4–11
Plug braking resistor, control check, 2–3
PROFIBUS interface configuration, 2–4
Protection against unauthorized interventions, 4–11

Q

Qualified personnel, 1–2

R

Release, 1–7
RESET, 2–6

S

Safety instructions, 1–4
Safety markings, 1–3
Saving all data, 5–10
scs file
 edit, 4–7
 send, 4–7
 transmit to drive, 6–1
Selecting the language, 4–9
Series commissioning, 6–1
 Loading files, 6–1
Signals, I/O, 8–4
Software version, 8–1
Spare parts, 1–6
Speed controller, 7–3

T

Temperature warning, via OUT2, 5–5
Template, filling in, 8–6
Test, 7–1
Test activities, 1–5
Torque monitoring, 5–7
Trademarks, 1–8

U

User groups, 4–11

V

Velocity control, 3–8
Velocity control with actual value feedback, 3–10

Notes:

Bosch Automation Technology

Australia

Robert Bosch (Australia) Pty. Ltd.
Head Office
Cnr. Centre - McNaughton Roads
P.O. Box 66
AUS-3168 Clayton, Victoria
Fax (03) 95 41 77 03

Great Britain

Robert Bosch Limited
Automation Technology Division
Meridian South Meridian Business Park
GB-LE3 2WY Braunstone
Leicestershire
Fax (01 16) 28-9 28 78

Canada

Robert Bosch Corporation
Automation Technology Division
6811 Century Avenue
CAN-Mississauga, Ontario L5N 1R1
Fax (905) 5 42-42 81

USA

Robert Bosch Corporation
Automation Technology Division
Fluid Power Products
7505 Durand Avenue
USA-Racine, Wisconsin 53406
Fax (414) 5 54-81 03

Robert Bosch Corporation
Automation Technology Division
Factory Automation Products
816 East Third Street
USA-Buchanan, MI 49107
Fax (616) 6 95-53 63

Robert Bosch Corporation
Automation Technology Division
Industrial Electronic Products
40 Darling Drive
USA-Avon, CT 0 60 01-42 17
Fax (860) 4 09-70 80

We reserve the right to make technical alterations

Your concessionary

BOSCH



Robert Bosch GmbH
Geschäftsbereich
Automationstechnik
Antriebs- und Steuerungstechnik
Postfach 11 62
D-64701 Erbach
Fax +49 (0) 60 62 78-4 28